

CENTURY®

LEGENDARY LEADERSHIP



OWNER'S MANUAL
INDUSTRIAL SERIES 30 LCG
DUAL REAR WHEELS
STANDARD CB
INSTALLATION, OPERATION, MAINTENANCE & PARTS

NOTE: MANUAL including SPECIFICATIONS, subject to change without notice
All ratings specified are based on structural factors only,
not vehicle capacities or capabilities.

CENTURY®

Miller Industries Towing Equipment Inc.
8503 Hilltop Drive
Ooltewah, Tennessee 37363

FORM NO. 0540015SCB
REV. 8/14
PRICE \$25.00

Phone (423) 238-4171 • FAX (423) 238-5371

LIMITED WARRANTY

MILLER INDUSTRIES TOWING EQUIPMENT INC., hereinafter referred to as MILLER, warrants to the original purchaser that each new MILLER Carrier will be free from defects in material and workmanship for a period of one (1) year from the date of purchase. The purchaser must promptly notify MILLER in writing of any failure in material or workmanship. In no event shall such notification be received by MILLER later than twelve (12) months from date of delivery.

The obligation under this warranty, statutory or otherwise, is limited to the repair or replacement at our factory, or at a point designated by us, of such part or parts as shall appear to us upon inspection to be defective in material or workmanship. New or remanufactured parts will be used for any replacement.

This warranty does not obligate MILLER to bear the cost of labor or transportation charges in connection with the replacement or repair of any parts found to be defective, nor shall it apply to a product upon which repairs or alterations have been made unless authorized by us.

MILLER shall in no event be liable for any incidental or consequential damages or contingent arising out of the failure of any parts or products to operate properly. NO IMPLIED, EXPRESS, OR STATUTORY WARRANTY OTHER THAN STATED HEREIN IS MADE OR AUTHORIZED TO BE MADE BY OR FOR US, INCLUDING, BUT NOT LIMITED TO, THE IMPLIED WARRANTIES OF MERCHANTABILITY AND FITNESS FOR A PARTICULAR PURPOSE.

MILLER makes no warranty, express or implied, as to finished products manufactured or supplied by another manufacturer or supplier by MILLER to purchaser, including, but not limited to, any vehicle to which a MILLER product may be affixed or accessories or wire rope (cable), and expressly disclaims any implied warranties of merchantability or fitness for a particular purpose as to such equipment or products. This language shall in no way affect or diminish the rights of purchaser to rely on such warranties as are extended by such manufacturers or suppliers.

MILLER, whose policy is one of continuous improvement, reserves the right to improve its product through changes in design or materials as it may deem desirable without being obligated to incorporate such changes in products of prior manufacture.

IT IS EXPRESSLY UNDERSTOOD THAT THERE IS NO IMPLIED WARRANTY THAT MILLER CARRIERS SHALL BE FIT FOR THE PURPOSE OF LIFTING OR MOVING PERSONS OR OTHER IMPROPER USE. THIS WARRANTY IS NOT TRANSFERABLE.



Miller Industries Towing Equipment Inc.
8503 Hilltop Drive
Ooltewah, Tennessee 37363
Telephone (423) 238-4171

SERIAL NUMBER

Section VI - PARTS

This Section is provided by the manufacturer for the purpose of ordering any component part of the **Industrial LCG Series Car Carrier** that may be required when part replacement is necessary. Be certain to use only original equipment replacement parts for warranty purposes as well as for keeping your **Industrial LCG Series Car Carrier** in its original state and optimum operating capacities.

When ordering replacement or spare parts be sure to provide the following information to your carrier manufacturer authorized representative.

1. **Manual Number & Date of Publication**
2. **Manual Page Number**
3. **Page Title**
4. **Reference Number of Part Desired**
5. **Part Number**
6. **Part Description**
7. **Quantity of Part Desired**

Providing this information will help ensure that the correct parts will be delivered to you in an expedient manner without delay. Should additional information be required for repair or replacement of certain components, contact **Miller Industries, Hermitage, PA, Phone: 724-981-3328, FAX 724-981-5260.**

The Manufacturer reserves the right, without notice or obligation, to improve or modify their products, which may change the specifications, models and feature availability.

Section VI - PARTS (cont'd)

SERIES 30 LCG DRW BED ASSEMBLY REMOVABLE TUBE RAIL

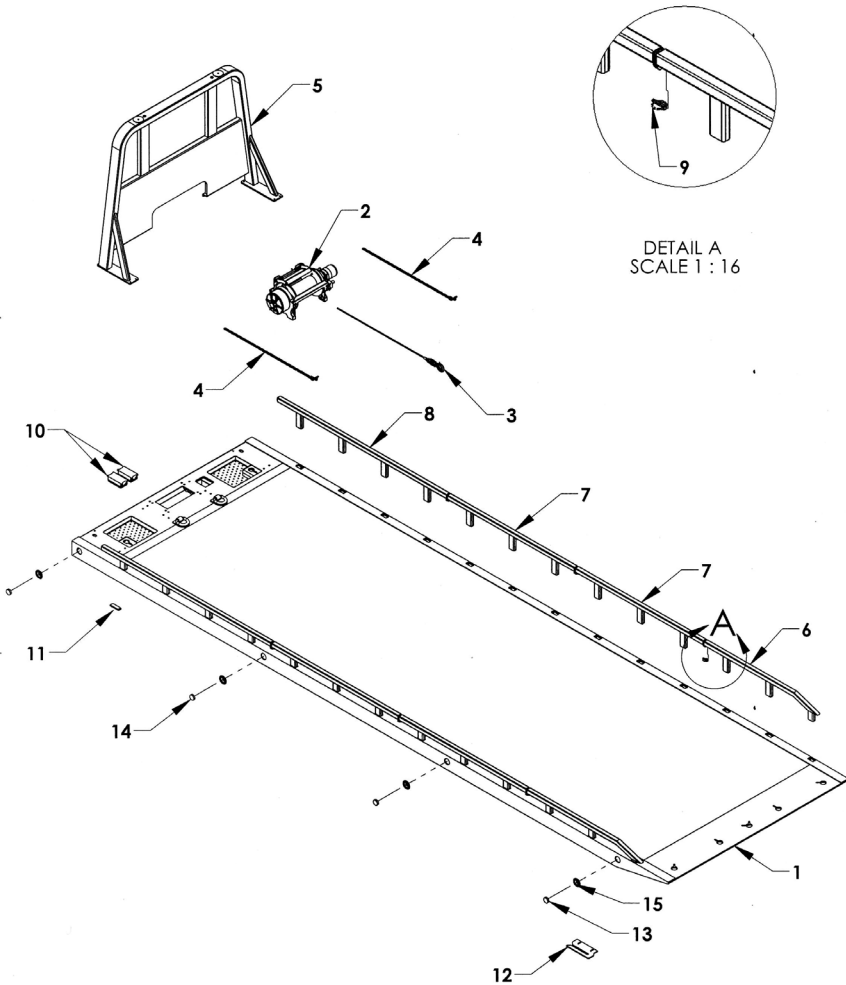

NOTES:

1. To order a replacement bed, provide the carrier serial number. Serial number look-up provides construction information about the bed regarding length and width as well as options such as floor plate, style of sides, winch and number of chain-locks.
2. The mounting location of the slideback cylinder on the bed correlates to the subframe geometry, which is built to fit the chassis upon which it is mounted.

Section VI - PARTS (cont'd)
SERIES 30 INDUSTRIAL LCG BED ASSEMBLY
REMOVABLE TUBE RAIL

REF. NO.	QPU	PART NUMBER	DESCRIPTION
1	1	3028430LDXXX-FW1	SERIES 30 INDUSTRIAL LCG BED WELDMENT
2	1	7112014	10 TON WARN WINCH ASSEMBLY
	1	7113014	15 TON WARN WINCH ASSEMBLY
3	1	0306034	WINCH CABLE ASSEMBLY - 9/16 x 75 FT
4	2	0301932	FRONT SAFETY CHAIN ASSEMBLY - 5/16 x 10'
5	1	35FL050	LCG CAB PROTECTOR WELDMENT - 50 INCHES
	1	35FL052	LCG CAB PROTECTOR WELDMENT - 52 INCHES
	1	35FL056	LCG CAB PROTECTOR WELDMENT - 56 INCHES
	1	35FL060	LCG CAB PROTECTOR WELDMENT - 60 INCHES
	1	35FL063	LCG CAB PROTECTOR WELDMENT - 63 INCHES
	1	35FL065	LCG CAB PROTECTOR WELDMENT - 65 INCHES
	1	35FL068	LCG CAB PROTECTOR WELDMENT - 68 INCHES
6	2	346064	REAR REMOVABLE TUBE RAIL - STEEL (3 POST)
7	2	346071M	MID REMOVABLE TUBE RAIL - STEEL (3 POST)
8	2	346095F	FRONT REMOVABLE TUBE RAIL - STEEL (4 POST)
9	6	0306070	LYNCH PIN
10	2	98710	JUNCTION BOX - 10 POST
11	2	33415	BEARING PAD-LOWER MAIN SILL
12	1	33813	ANTI-TILT PLATE
13	2	0311512	LED MARKER LIGHT, RED
14	6	0311513	LED MARKER LIGHT, AMBER
15	8	0311516	GROMMET, ROUND RUBBER

Section VI - PARTS (cont'd)
INDUSTRIAL LCG SUBFRAME
COMPONENTS

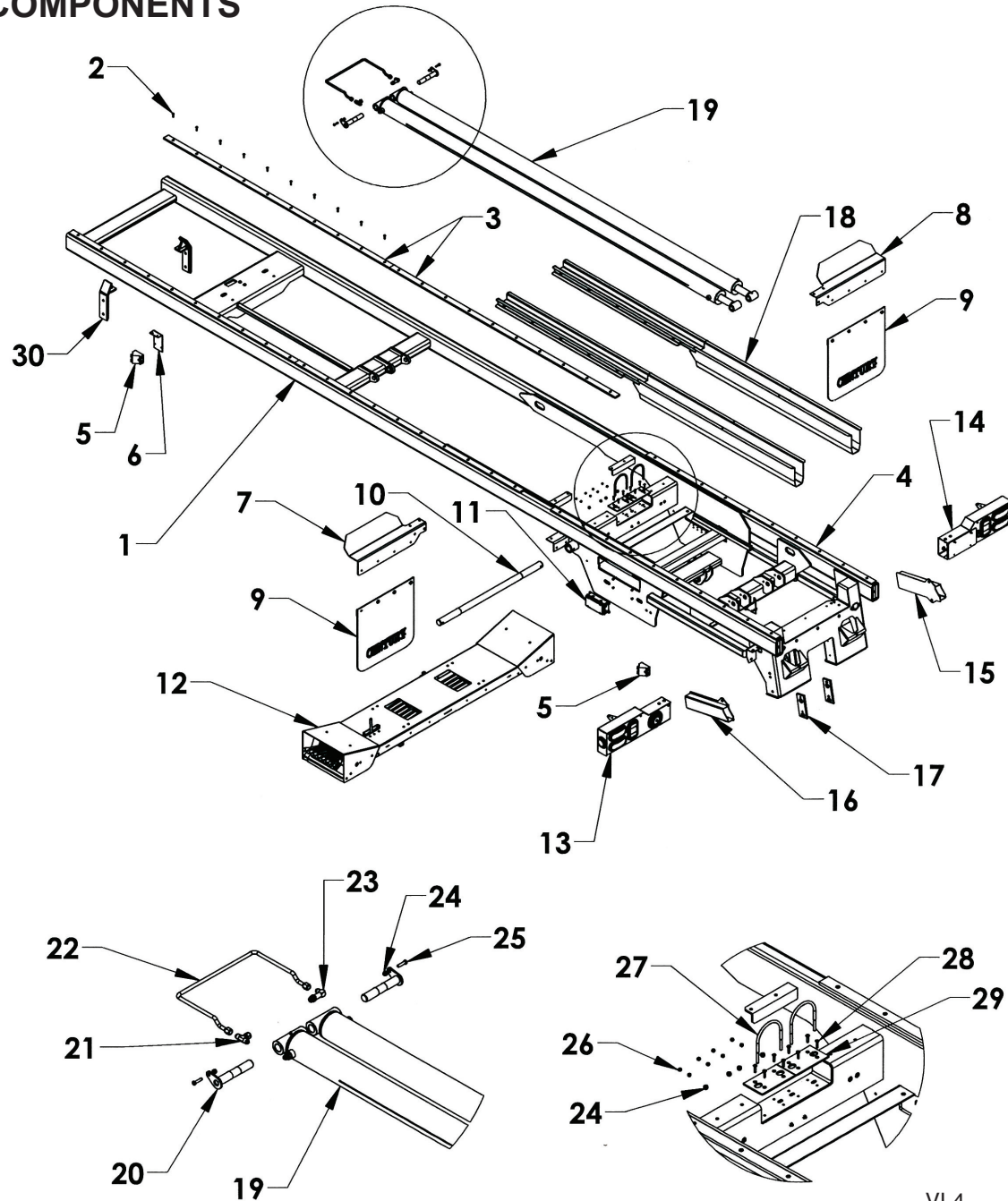

Section VI - PARTS (cont'd)

INDUSTRIAL LCG SUBFRAME COMPONENTS

REF NO.	PART #	DESCRIPTION	QTY
1	0809796-23	S30 LCG DRW SUBFRAME	1
2	81121	BOLT 5/16-18 UNC ALLEN COUNTERSUNK	60
3	33308R2	S30 SUBFRAME WEAR STRIP 1/2 x 2 x 96 BLACK	4
4	33308N2	S30 SUBFRAME WEAR STRIP 1/2 x 2 x 96 GRAY	2
5	74345	DUAL COUNTERBALANCE VALVE	2
6	13063-30	COUNTERBALANCE VALVE MTG PLATE - 30 LCG DRW	1
7	0751024-29L	WIDE AL SPLASH GUARD L REAR R FRONT	1
8	0751024-29R	WIDE AL SPLASH GUARD R REAR L FRONT	1
9	0308419	CENTURY MUDFLAP	2
10	0751264	20 LCG SUBFRAME HINGE PIN 1.975 x 43.375	1
11	98710	JUNCTION BOX	1
12	183126	6 SPOOL CONTROL STATION	1
13	0940328L	CENTURY LCG GEN 2 TAIL LIGHT HOUSING GROUP - L	1
14	0940328R	CENTURY LCG GEN 2 TAIL LIGHT HOUSING GROUP - R	1
15	1605610R	L-ARM STORAGE TUBE 6000# - RIGHT	1
16	1605610L	L-ARM STORAGE TUBE 6000# - LEFT	1
17	0750409	STABILIZER WHEEL LIFT GUIDE PAD	2
18	0809659	HOSE TRAY WELDMENT - 132" SLIDEBACK	2
19	72A40132	SLIDEBACK CYLINDER - 3.5 BORE x 120 STROKE	2
20	1302720A	20 LCG SLIDEBACK CYLINDER PIN WELDMENT	2
21	ADAPTER	ADAPTER - 203101 - 08 x 08	1
22	72H30FT	30 LCG S/B CYLINDER FLUID PIPE ASSEMBLY	1
23	ADAPTER	ADAPTER - 206209 - 08 x 08	1
24	-	NYLON LOCK NUT - 3/8-16 UNC	6
25	-	BOLT, HHCS 3/8-16 UNC x 1-1/2	2
26	-	NYLON LOCK NUT 5/16-18 UNC	8
27	81287	U-BOLT, 3/8-16 UNC - 4.562 x 6	2
28	-	BOLT, ALLEN COUNTERSUNK 1/4-20 UNC X 1-1/4	8
29	0751223	LCG 12/16/20 S/B CYLINDER SUPPORT PAD	2
30	0809975	SUBFRAME ALIGNMENT GUIDE	2

XX = FS (FIXED STABILIZER)
 HS (HYDRAULIC STABILIZER)
 WS (WHEEL-LIFT STABILIZER)

NOTE:

To order a replacement subframe, provide the carrier serial number. Series 30 subframes are built to order to fit specific chassis cab-to-axle, crossmember, and suspension geometry to avoid chassis modifications. Serial number look-up provides the subframe construction geometry regarding the hinge and cylinder box locations.

Section VI - PARTS (cont'd)

SERIES 30 LCG DUAL REAR WHEELS 6K TELESCOPING PINTLE

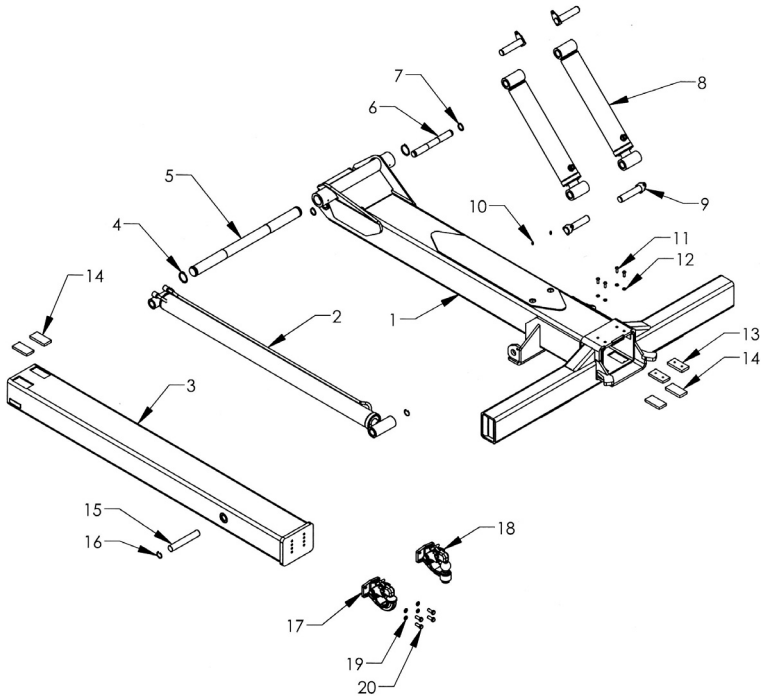

REF	PART #	DESCRIPTION	QTY
1	10260605	6K UNDERLIFT OUTER BOOM TUBE WELDMENT	1
2	72A30052	CYLINDER - STABILIZER/WHEEL LIFT EXTENSION	1
3	10262P	INNER PINTLE BOOM	1
4	86200E	SNAP RING - 2" EXTERNAL	2
5	143122	4K/6K UNDERLIFT HINGE PIN	1
6	14313	PIN-W/L EXTENSION CYLINDER BASE END	1
7	86125E	SNAP RING 1-1/4" EXTERNAL	2
8	72A350154	WHEEL-LIFT LIFT CYLINDER - LCG20	2
9	0809660	KEEPER PIN 1.250 x 5.500	4
10	7B130	GREASE FITTING 1/4-28 UNF	2
11		BOLT, BHSC 3/8-16 UNC x 1	4
12		3/8 LOCK WASHER	4
13	63595H	WEAR PAD NYLATRON NSM 1/2 x 2 x 4 W/HOLES	2
14	63595	WEAR PAD NYLATRON NSM 1/ x 2 x 4	4
15	14314	PIN - W/L EXTENSION CYLINDER ROD END	1
16	86125I	SNAP RING 1-1/4 " INTERNAL	3
17	A3020H	PINTLE HOOK ATTACHMANT	1
18	A3020	PINTLE BALL ATTACHMENT	1
19		1/2 LOCK WASHER	4
20		BOLT, HEX, 1/2-13 x 1-1/4	4

Section VI - PARTS (cont'd)
SERIES 30 LCG DUAL REAR WHEELS
6K PIVOTING PINTLE

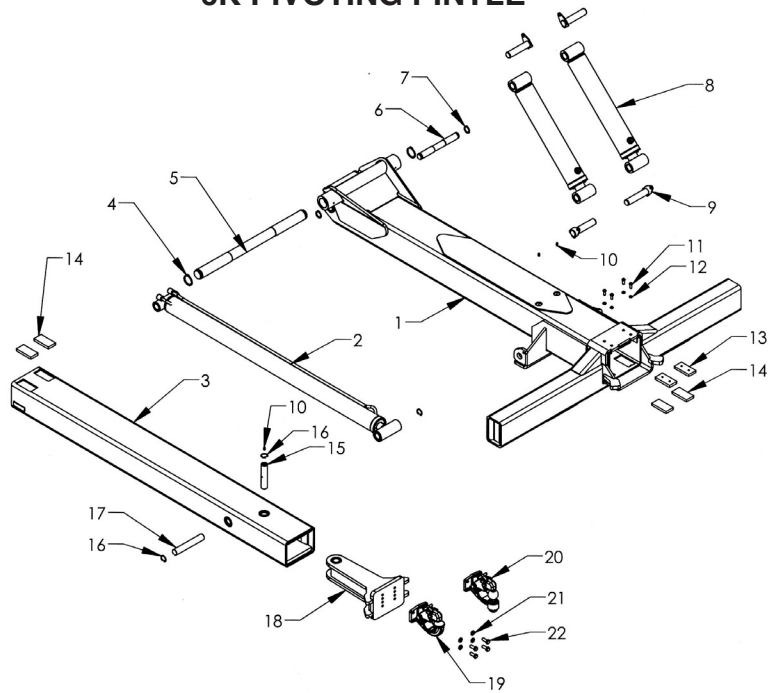

REF	PART #	DESCRIPTION	QPU
1	10260605	6K UNDERLIFT OUTER BOOM TUBE WELDMENT	1
2	72A30052	CYLINDER - STABILIZER/WHEEL LIFT EXTENSION	1
3	10262-PP	INNER PINTLE BOOM	1
4	86200E	SNAP RING - 2" EXTERNAL	2
5	143122	4K/6K UNDERLIFT HINGE PIN	1
6	14313	PIN-W/L EXTENSION CYLINDER BASE END	1
7	86125E	SNAP RING 1-1/4" EXTERNAL	2
8	72A350154	WHEEL-LIFT LIFT CYLINDER - LCG20	2
9	0809660	KEEPER PIN 1.250 x 5.500	4
10	7B130	GREASE FITTING 1/4-28 UNF	3
11	-	BOLT, BHSC 3/8-16 UNC x 1	4
12	-	3/8 LOCK WASHER	4
13	63595H	WEAR PAD NYLATRON NSM 1/2 x 2 x 4 W/HOLES	2
14	63595	WEAR PAD NYLATRON NSM 1/1 x 2 x 4	4
15	14314PP	PIN - PIVOTING PINTLE HEAD	1
16	86125I	SNAP RING 1-1/4 " INTERNAL	3
17	14314	PIN-W/L EXTENSION CYLINDER ROD END	1
18	143350	PIVOTING PINTLE HEAD WELDMENT - 6K	1
19	A3020H	PINTLE HOOK ATTACHMANT	1
20	A3020	PINTLE BALL ATTACHMENT	1
21	-	1/2 LOCK WASHER	4
22	-	BOLT, HEX, 1/2-13 x 1-1/4	4

Section VII - PARTS (cont'd)
 INDUSTRIAL LCG TAIL LIGHT COMPONENTS

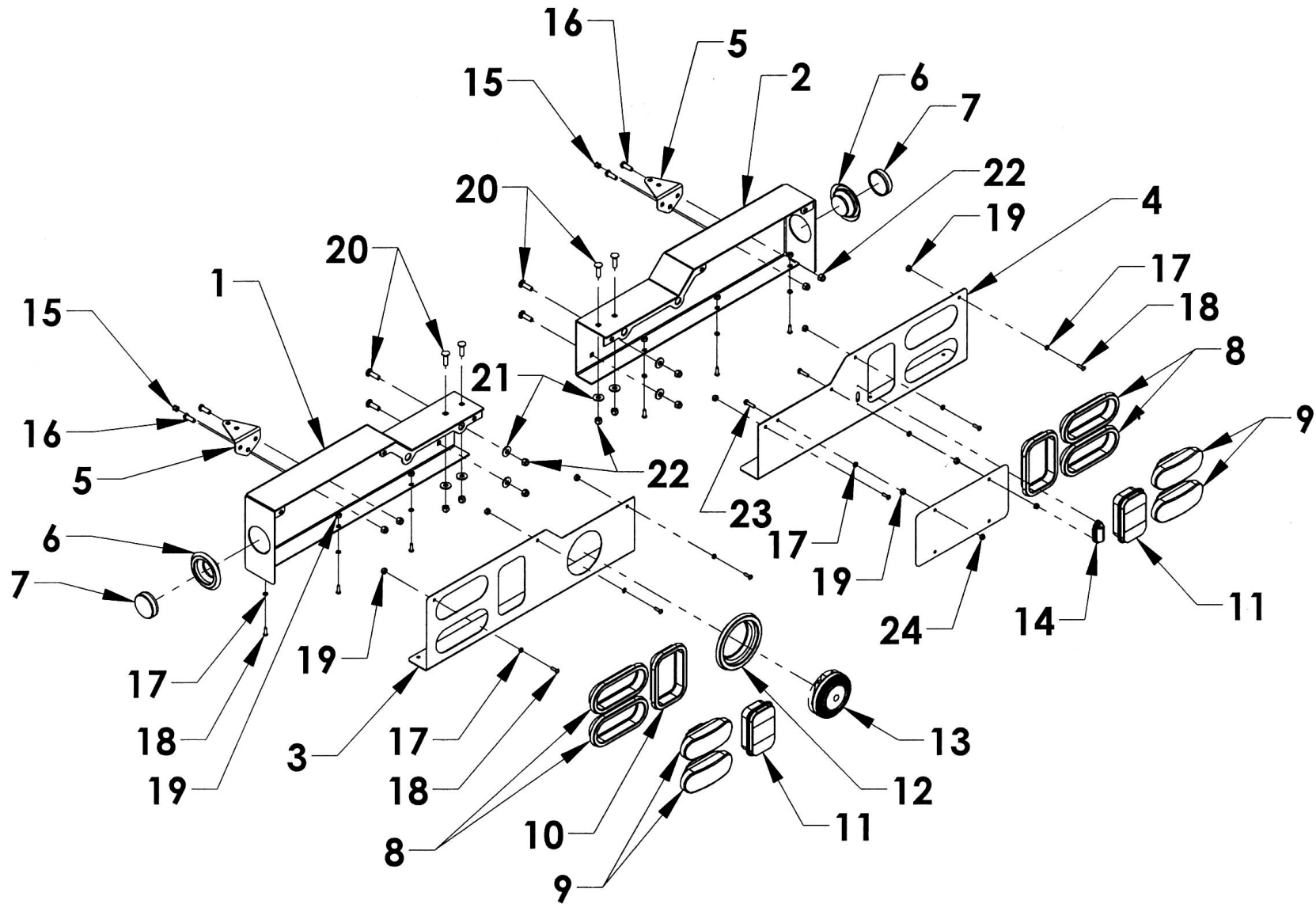

Section VI - PARTS

30 LCG TAIL LIGHT COMPONENTS

REF. NO.	NO. REQ'D	PART NUMBER	DESCRIPTION
1	1	0809517L	TAIL LIGHT HOUSING WELDMENT - LEFT
2	1	0809517R	TAIL LIGHT HOUSING WELDMENT - RIGHT
3	1	0751892L	12/16/20 LCG TAIL LIGHT BEZEL - LEFT G2
4	1	0751892R	12/16/20 LCG TAIL LIGHT BEZEL - RIGHT G2
5	2	0750672	WORK LIGHT MOUNTING BRACKET
6	2	0311516	2-1/2 IN. MARKER LIGHT GROMMET
7	2	0311512	2-1/2 IN. RED MARKER LIGHT
8	4	0311503	6 IN. OVAL GROMMET
9	4	0311498	6 IN. OVAL RED LIGHT
10	2	0311511	CARRIER TAIL LIGHT GROMMET
11	2	0311510	CARRIER BACK UP LIGHT
12	1	0311528	BACK UP ALARM GROMMET
13	1	0306385	BACK UP ALARM
14	1	0311525	LICENSE PLATE LIGHT
15	2	0306050	TAIL LIGHT WIRE GROMMET
16	4	-	BOLT, HHCS 3/8-16 UNC x 1
17	14	-	LOCK WASHER - 1/4
18	12	-	BOLT, RHMS 1/4-20 UNC x 3/4
19	14	-	HEX NUT 1/4-20 UNC
20	8	-	BOLT, CARRIAGE 3/8-16 UNC x 1-1/4 SS
21	8	-	FLAT WASHER - 3/8
22	12	-	NYLON LOCK NUT 3/8-16 UNC
23	2	-	BOLT, HHCS 1/4-20 UNC x 1
24	2	-	NYLON LOCK NUT 1/4-20 UNC

Section VI - PARTS (cont'd)

INDUSTRIAL LCG DOCK STABILIZER

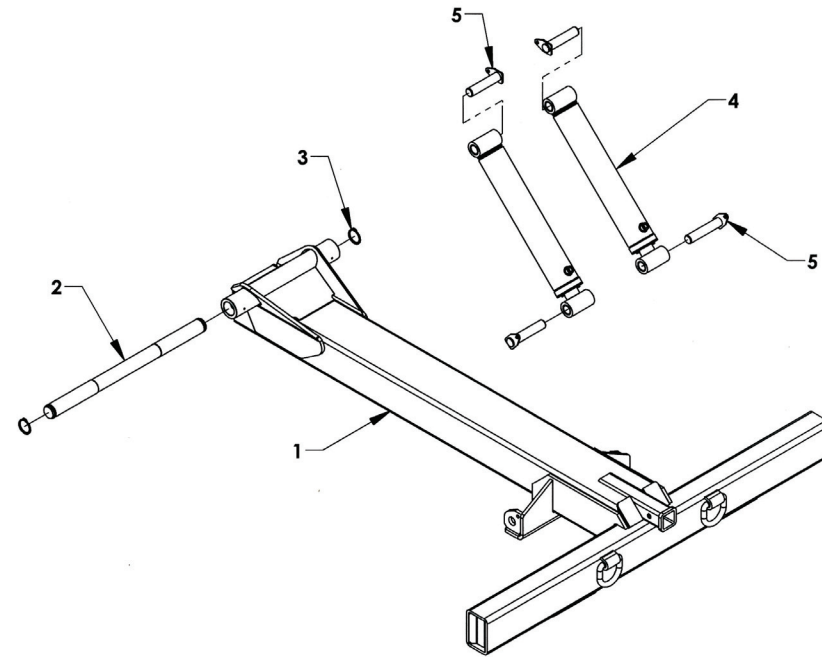

REF	PART #	DESCRIPTION	QPU
1	0809673	INDUSTRIAL LCG DOCK STABILIZER WLMT	1
2	143122	4K/6K UNDERLIFT HINGE PIN	1
3	86200E	SNAP RING 2" EXTERNAL	2
4	72A350154	W/L LIFT CYLINDER	2
5	0809660	KEEPER PIN 1.250 x 5.500	4

Section VI - PARTS (cont'd)
INDUSTRIAL 30 LCG 6000 LB. WHEEL LIFT
TIRE RESTRAINT ASSEMBLY

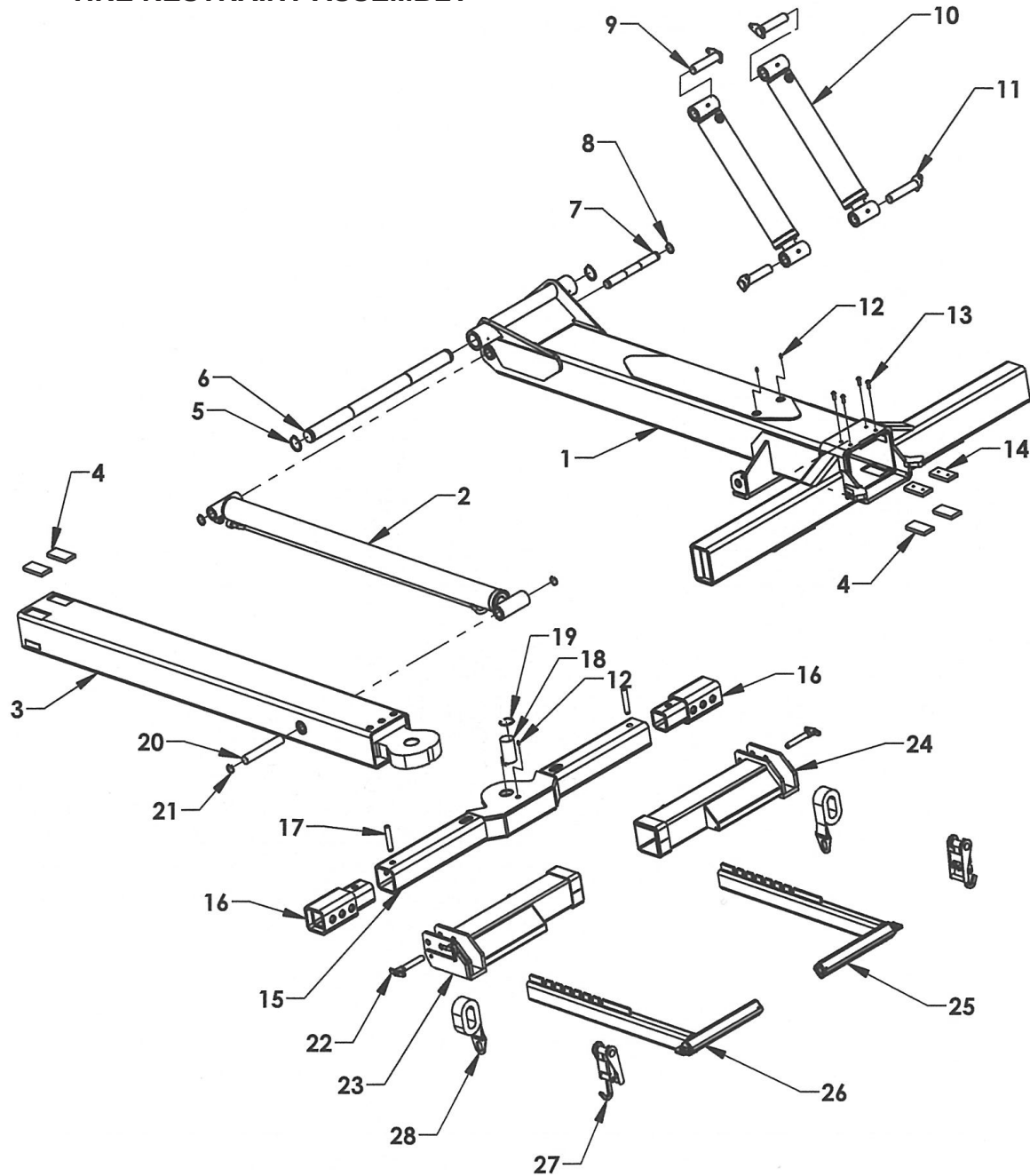

Section VI - PARTS

INDUSTRIAL 30 LCG WHEEL LIFT 6000 LB.

REF	PART #	DESCRIPTION	QPU
1	10260605	LCG 6000 LB. T-BOOM WELDMENT	1
2	7212730	CYLINDER-STABILIZER/WHEEL LIFT EXTENSION	1
3	10262	LCG 6000 LB. W/L INNER BOOM TUBE WELDMENT	1
4	63595	WEAR PAD NYLATRON NSM 1/2 x 2 X 4	4
5	86200E	SNAP RING - 2 IN. EXTERNAL	2
6	143122	4K/6K UNDERLIFT HINGE PIN	1
7	14313	PIN - W/L EXTENSION CYLINDER BASE END	1
8	86125E	SNAP RING - 1-1/4 IN. EXTERNAL	2
9	0806094	KEEPER PIN WELDMENT - 1.25 x 5.50	2
10	72A350154	W/L LIFT CYLINDER - LCG 20	2
11	0809660	KEEPER PIN WELDMENT - 1.25 x 5.875	4
12	7B130	GREASE FITTING - 1/4-28	3
13	-	BOLT, BHCS - 3/8-16 UNC x 1	4
14	63595H	WEAR PAD NYLATRON NSM 1/2 x 2 x 4 WITH HOLES	2
15	685102	CROSSBAR WELDMENT	1
16	68530	CROSSBAR EXTENSION	2
17	66245	CROSSBAR EXTENSION PIN	2
18	66430	CROSSBAR PIVOT PIN	1
19	86200I	SNAP RING - 2 IN. INTERNAL	1
20	14314	PIN - W/L EXTENSION CYLINDER ROD END	1
21	86125I	SNAP RING - 1/4 IN. INTERNAL	2
22	84922	T-PIN - 3/4 x 3-1/2 IN. QUICKPIN	2
23	66267L	WHEEL GRID ASSEMBLY - LEFT	1
24	66267R	WHEEL GRID ASSEMBLY - RIGHT	1
25	66250R	WHEEL RETAINER - 6000 LB - RIGHT	1
26	66250L	WHEEL RETAINER - 6000 LB - LEFT	1
27	65280A	W/L RATCHET AND HOOK ASSEMBLY	2
28	65285	WHEEL STRAP WITH D-RING - YELLOW	2

Section VI - PARTS
6K/10K UNDERLIFT ATTACHMENTS

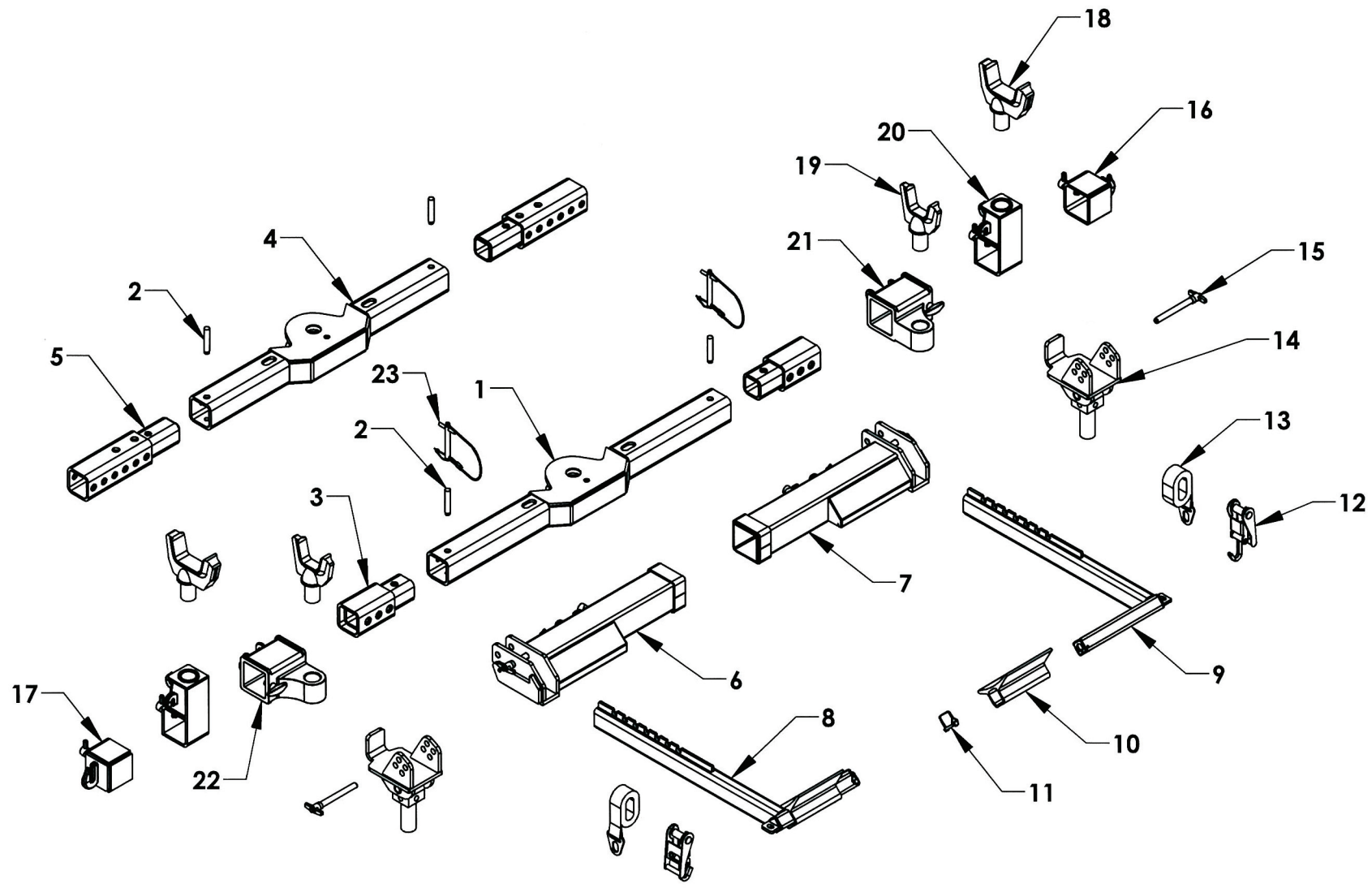

Section VI - PARTS

6K/10K UNDERLIFT ATTACHMENTS

REF	PART #	DESCRIPTION	QPY
1	685102	CROSSBAR 4 x 4 x 53.25	1
2	68545	CROSSBAR EXTENSION PIN	2
3	68530	CROSSBAR EXTENSION	2
4	616090	CROSSBAR 4 x 4 x 44.625 (OPT)	1
5	6460950	CROSSBAR EXTENSION (OPT)	2
6	68260L	WHEEL GRID-LEFT	1
7	68260R	WHEEL GRID - RIGHT	1
8	66250L	6000 LB. L-ARM - LEFT	1
9	66250R	6000 LB. L-ARM - RIGHT	1
10	65245	REMOVABLE PAN	2
11	84911	5/16 SAFETY SNAP PIN	2
12	65280A	WHEEL LIFT RATCHET & HOOK ASSEMBLY	2
13	65285	WHEEL STRAP WITH D-RING	2
14	66320	SPRING SHACKLE ADAPTOR (OPT)	2
15	84923	T-PIN .75 x 6	2
16	66A210R	CROSSBAR END HOOK - RIGHT (OPT)	1
17	66A210L	CROSSBAR END HOOK - LEFT (OPT)	1
18	663545 (0200019)	FRAME FORK SHORT 4-1/2 IN. CAST (OPT)	2
19	663530 (0200018)	FRAME FORK - 3 INCH CAST (OPT)	2
20	66330	ELEVATED FORK HOLDER (OPT)	2
21	66285R (0803580)	OFFSET FORK HOLDER - CAST - RIGHT (OPT)	1
22	66285L (0803581)	OFFSET FORK HOLDER - CAST - LEFT (OPT)	1
23	0902378	RETAINER PIN (USE W/OFFSET CAST FORKS HLDRS)	1

Section VI - PARTS
6-SPOOL CONTROL STATION

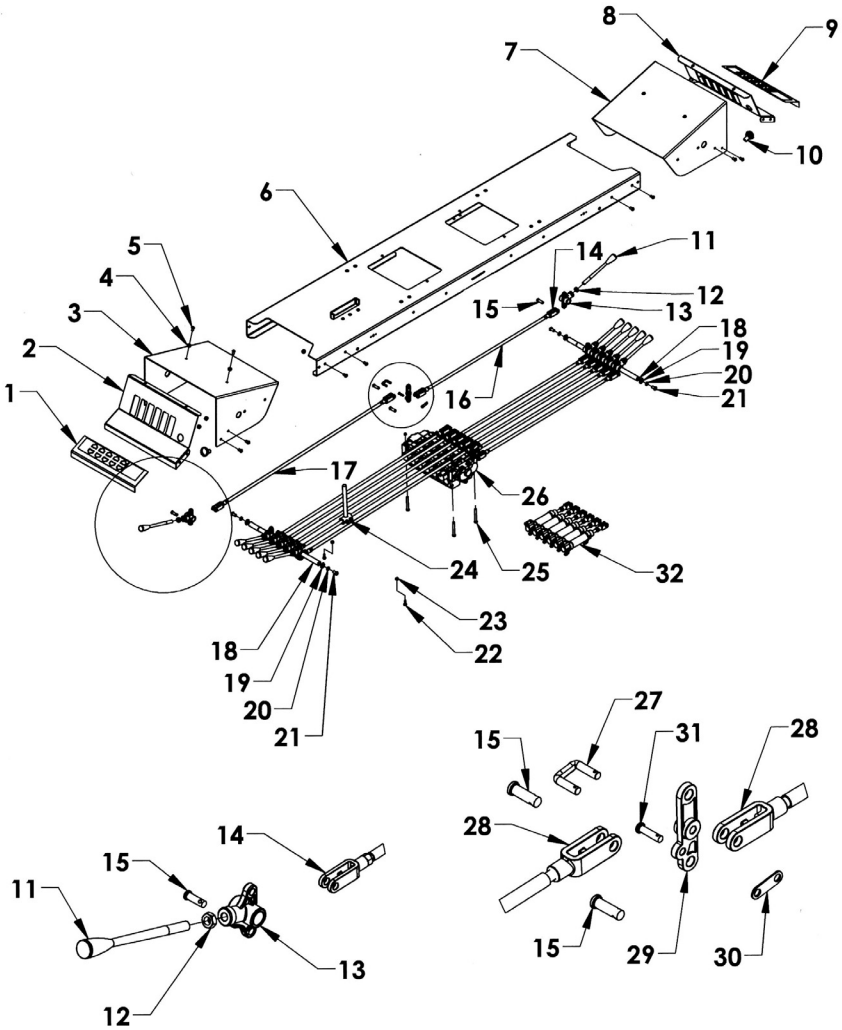

Section VI - PARTS

6-SPOOL CONTROL STATION

REF. NO.	NO. REQ'D	PART NUMBER	DESCRIPTION
1	1	18212L/18214L	5 SPOOL/6 SPOOL CONTROL PLACARD-LEFT
2	1	18126L	CONTROL PANEL - LEFT
3	1	181273L	CONTROL HOOD - LEFT
4	23		NYLON LOCK NUT 5/16-18 UNC
5	16		BOLT, BUTTON HEAD 5/16-18 UNC x 5/8
6	1	181286W	CONTROL BOX ARM WELDMENT - 79.5 IN.
7	1	181273R	CONTROL HOOD - RIGHT
8		18126R	CONTROL PANEL - RIGHT
9	1	18212R/18214R	5 SPOOL/6 SPOOL CONTROL PLACARD - RIGHT
10	1	0320031	CONTROL LIGHT - 2 WIRE
11	2	0320048-GR	GREEN CONTROL HANDLE
	4	0320048-BL	BLUE CONTROL HANDLE
	2	0320048-RD	RED CONTROL HANDLE
	4	0320048-GY	GREY CONTROL HANDLE
12	12		JAM NUT 1/2-13 UNC ZINC PLATE
13	12	7A1155	CONTROL HANDLE PIVOT BASE
14	12	84530	CLEVIS - RIGHT HAND THREAD
15	24	84620	CLEVIS PIN, 3/8 x 1-1/8
16	6	7A528W	CONTROL ROD 28-1/2
17	6	7A538W	CONTROL ROD 37-3/4
18	2	7A5753-17	CONTROL HANDLE CROSS ROD 3/4 x 17
19	4	86075E	SNAP RING 3/4 EXTERNAL
20	4		LOCK WASHER 3/8
21	4		BOLT, BUTTON HEAD 3/8-16 UNC x 3/4
22	4		BOLT, HHCS 1/4-20 UNC x 3/4
23	4		NYLON LOCK NUT 1/4-20 UNC
24	1	0809904	ANTI-TILT CONTROL ROD WELDMENT
25	3		BOLT, HHCS 5/16 -18 UNC x 2-3/4
26	1	74116	VALVE BODY GRESEN 6 SPOOL
27	6	7A010LINK	CLEVIS LINK
28	12	84540	CLEVIS - LEFT HAND THREAD
29	6	7A121	BELL CRANK
30	6	7A010LINKPLATE	CLEVIS LINK PLATE
31	6	84610	CLEVIS PIN, 1/4 x 15/16
32	6	PC32850	AIR CYLINDER - 2 IN. STROKE

Section VI - PARTS

OUTBOARD 24 GALLON HYDRAULIC TANK GROUP

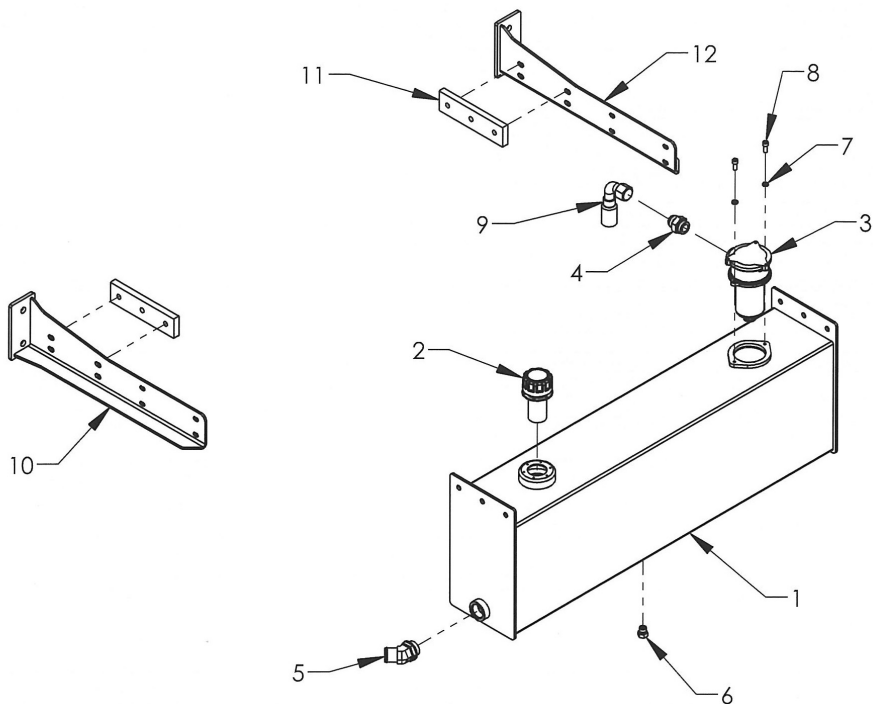

REF	PART #	DESCRIPTION	QPU
1	0809490	OUTBOARD 24 GALLON OIL RESERVOIR	1
2	76213G	FILLER/BREATHER CAP ASSEMBLY	1
3	76270	IN-TANK FILTER ASSEMBLY #16 SAE PORT	1
4	ADPTR202702 16x16	ADAPTOR 202702 16x16	1
5	ADPTR2061 20x24H	ADAPTOR 2061 20x24H	1
6	0403113	#8 O-RING PLUG - ADAPTOR 900598-8	1
7	82220	LOCK WASHER 3/8	2
8	81212	CAP SCREW 3/8-16 UNC x 7/8 SS	2
9	HOSEEND-16H-16JICF90	HOSE END - 16H - 16JICF90	1
10	37855R	UNV. TOOLBOX & OIL TNK MTG.BRKT-R	1
11	12826	TOOLBOX SHIM (FOR 49 IN. ALUM. BOX)	2
12	37855L	UNV. TOOLBOX & OIL TNK MTG BRKT-L	1

Section VI - PARTS

30 LCG TILT CYLINDER COMPONENTS (TANDEM AXLE CONFIGURATION)

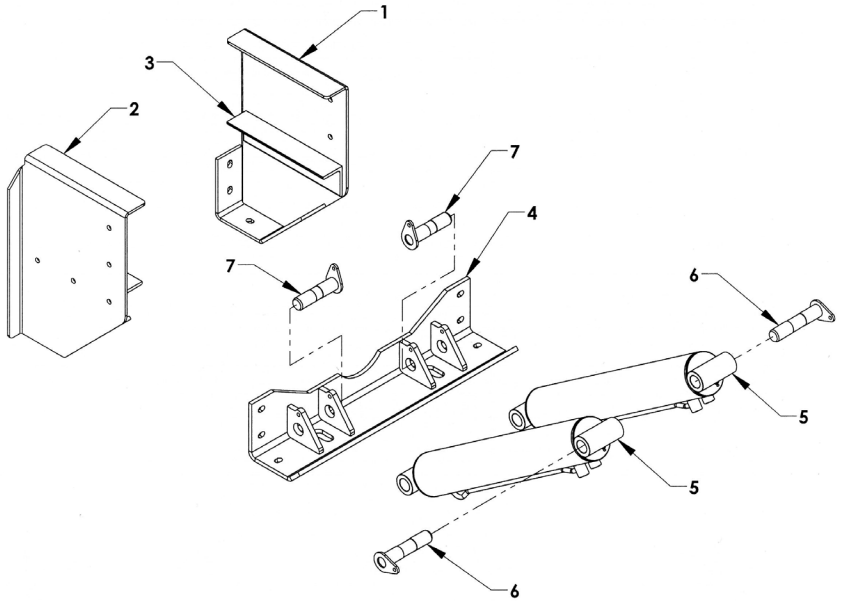

REF	PART #	DESCRIPTION	QPU
1	1A510R	TILT CYLINDER SADDLE - RIGHT	1
2	1A510L	TILT CYLINDER SADDLE - LEFT	1
3	1A514	UNDERFRAME SUPPORT ANGLE	2
4	1A550	CONNECTING ANGLE - LCG	1
5	72A450265	TILT CYLINDER - LCG - 4.5 BORE x 26.563 STROKE	2
	72A450305	TILT CYLINDER - LCG - 4.5 BORE x 30.563 STROKE	2
6	0809477	TILT CYLINDER BASE PIN	2
7	1A555	TILT CYLINDER ROD PIN	2

Section VI - PARTS

30 LCG TILT CYLINDER COMPONENTS (TRI-AXLE CONFIGURATION)

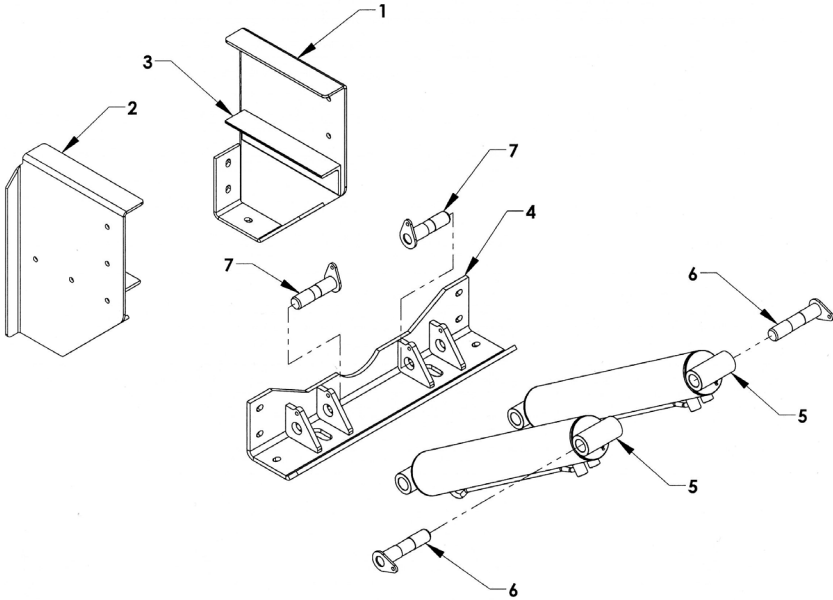

REF	PART #	DESCRIPTION	QPU
1	1A510TR	TILT CYLINDER SADDLE TRI-AXLE - RIGHT	1
2	1A510TL	TILT CYLINDER SADDLE TRI AXLE - LEFT	1
3	1A514	UNDERFRAME SUPPORT ANGLE	2
4	1A550	CONNECTING ANGLE - LCG	1
5	72A450335	TILT CYL - TRI-AXLEL - LCG - 4.5 BORE x 33.563 STROKE	2
6	0809477	TILT CYLINDER BASE PIN	2
7	1A555	TILT CYLINDER ROD PIN	2

Section VI - PARTS (cont'd)

INDUSTRIAL LCG MUDFLAP COMPONENTS

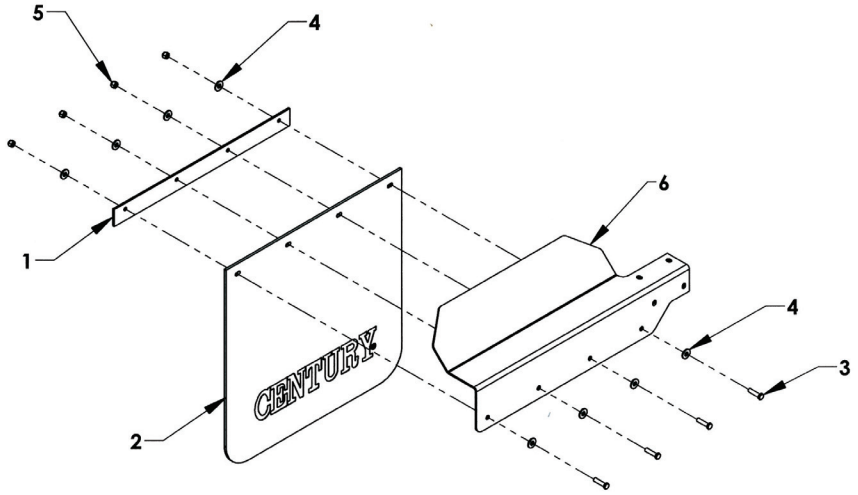

REF	PART #	DESCRIPTION	QPU
1	12359	MUDFLAP SUPPORT PLATE	1
2	0308419	CENTURY MUDFLAP 24 x 24	1
3	81240	3/8-16 UNC x 1-1/2	4
4	-	3/8 FLAT WASHER	8
5	-	3/8 NYLON LOCK NUT	4
6	0751024-29L	ALM SPLASH GUARD LFT REAR RGT FRONT	1
-	0751024-29R	ALM SPLASH GUARD RFT REAR LFT FRONT	2

Section VI - PARTS

DIRECT MOUNT PUMP

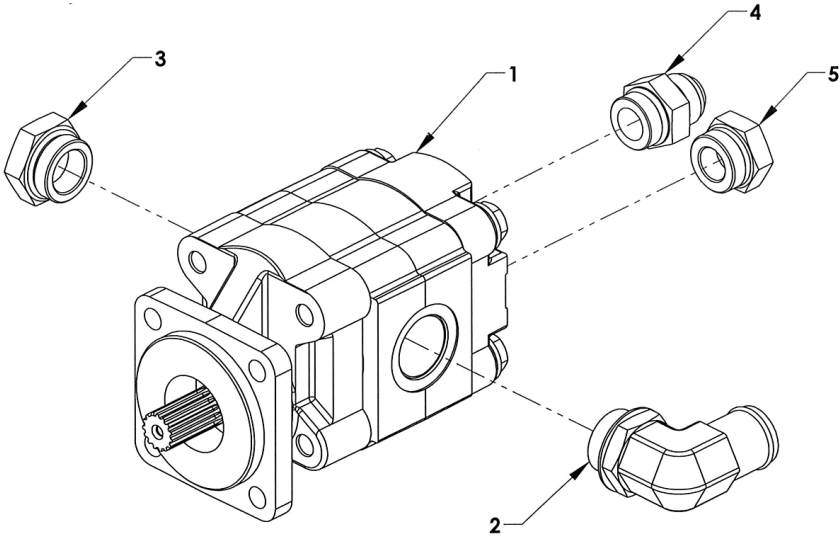

REF	PART #	DESCRIPTION	QPU
1	78006	PUMP-24 GPM , 1 IN. 15 SPLINE SHAFT, SAE 4-BOLT FLANGE	1
2	77C92	1-1/4 x 90 M-M O-RING x 1-1/2 NIPPLE	1
3	77620	1-1/4 O-RING PLUG 900598-20	1
4	779A8	1 O-RING x 1 JICF 202702 - 16 x 16	1
5	77616	1 O-RING PLUG 900598-16	1

Section VI - PARTS (cont'd)

WARN SERIES 20 PLANETARY WINCH GROUP

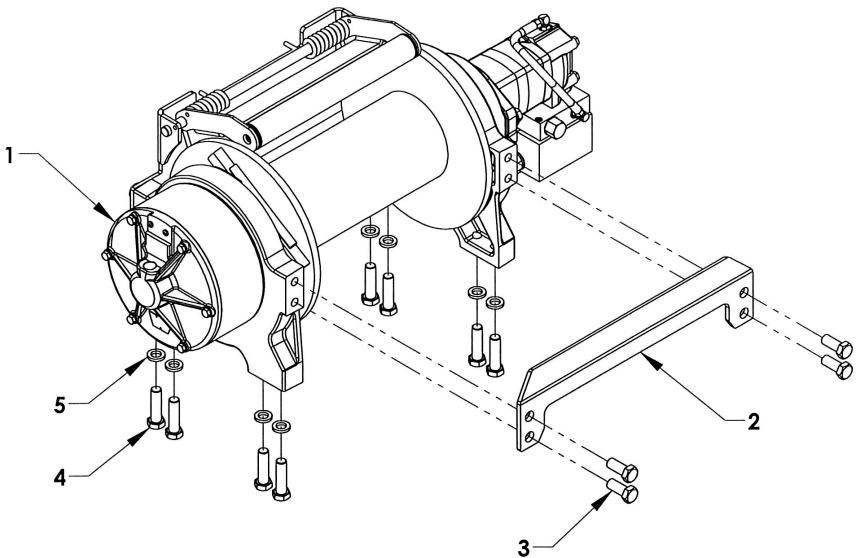

REF	PART #	DESCRIPTION	QPU
1	7112014	WARN SERIES 20 PLANETARY WINCH	1
2	0750984	DRUM SUPPORT CROSSBAR	7
3	81510	BOLT 5/8-11 UNC x 1-1/2 GR 5 ZINC PLATED	8
4	81522	BOLT 5/8-11 UNC x 2-1/4 GR 8 ZINC PLATED	8
5	82420	LOCK WASHER 5/8 ZINC PLATED	8

Section VI - PARTS (cont'd)

TRI-BOX PYLON

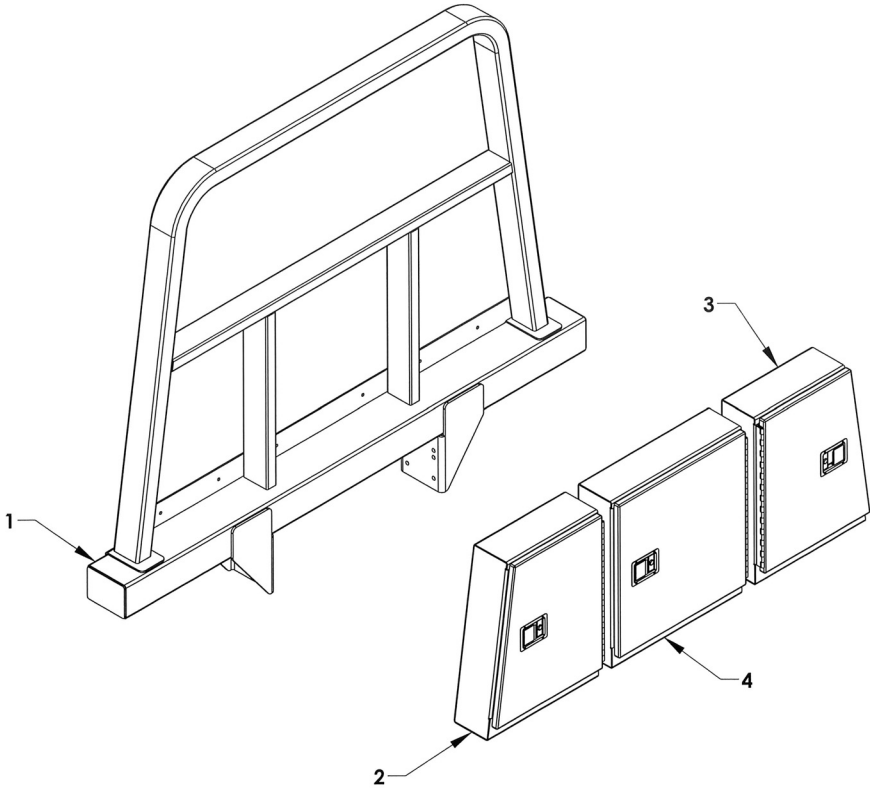

REF	PART #	DESCRIPTION	QPU
1	354656	FRAME MOUNTED PYLON BASE WLMT - 56 INCHES	1
	354660	FRAME MOUNTED PYLON BASE WLMT - 60 INCHES	1
	354663	FRAME MOUNTED PYLON BASE WLMT - 63 INCHES	1
	354668	FRAME MOUNTED PYLON BASE WLMT - 68 INCHES	1
2	374010L	PYLON BOX - LEFT	1
3	374010R	PYLON BOX - RIGHT	1
4	374020	PYLON BOX - CENTER	1
		BOX MOUNTING HARDWARE	
	81230	3/8-16 UNC x 1-1/4 HEX HD BOLT	12
	83211	3/8-16 UNC NYLON LOCK NUT	12
	82210	5/8 FLAT WASHER	24
		FRAME BRACKET HARDWARE	
	81520	5/8-11 UNC x 2 HEX HD BOLT	8
	83411	5/8-11 UNC NYLON LOCK NUT	8
	82410	5/8 FLAT WASHER	16

Section VI - PARTS

BODY LOCK ASSEMBLY - 364220K

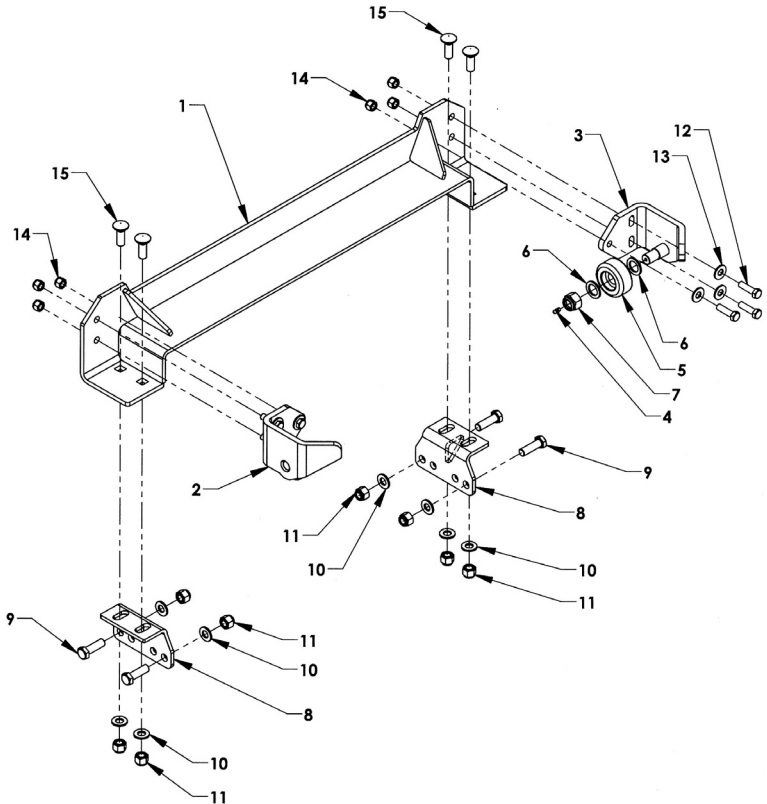

REF. NO.	NO. REQ'D	PART NUMBER	DESCRIPTION
1	1	364220	LCG BODY LOCK WELDMENT-SETBACK CAPABLE
2	1	36315L	BODY LOCK HOLD-DOWN - LEFT
3	1	36315R	BODY LOCK HOLD-DOWN - RIGHT
4	2	7B130	GREASE FITTING 1/4-28
5	2	36310	ROLLER WHEEL
6	4	-	FLAT WASHER 1
7	2	-	NYLON LOCK NUT, 7/8-14 UNF
8	2	0809183	MOUNTING BRACKET
9	4	-	BOLT, 5/8-11 HHCS UNC x 2 GRADE 5
10	8	-	FLAT WASHER 5/8
11	8	-	NYLON LOCK NUT, 5/8-11 UNC
12	6	-	BOLT, HHCS 1/2-20 UNF x 1-1/4
13	6	-	FLAT WASHER, 1/2 IN.
14	6	-	NYLON LOCK NUT, 1/2-20 UNF
15	4	-	CARRIAGE BOLT 5/8-11 x 1-3/4

Section VI - PARTS

PINTLE ATTACHMENT GROUP

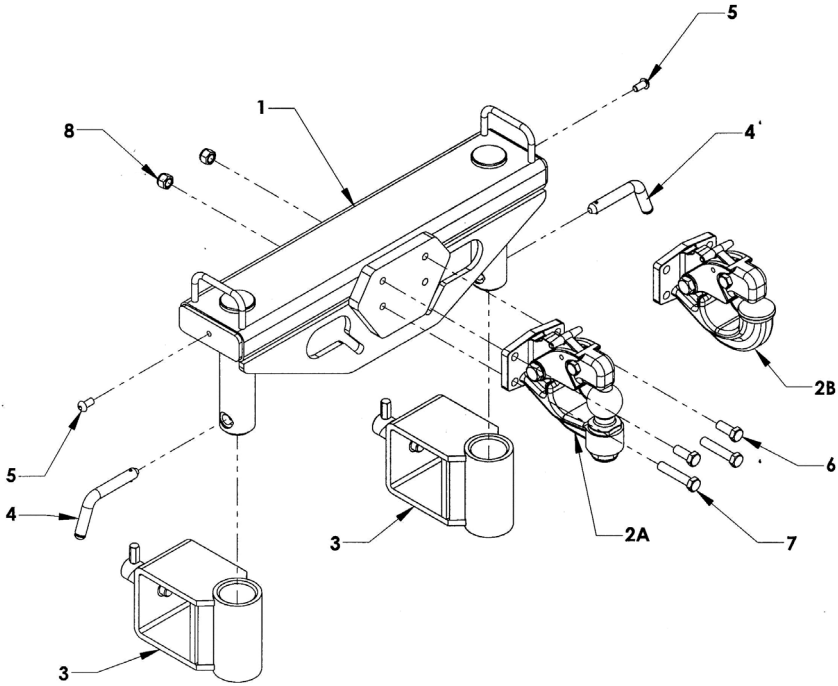

REF	PART #	DESCRIPTION	QPU
1	66370G	PINTLE HITCH GROUP	1
	66370W	PINTLE HITCH WELDMENT	1
2A	A3020	TOW BALL PINTLE HITCH	1
2B	A3020H	PINTLE HOOK	1
3	66280	FORK HOLDER - 4 IN. CROSSBAR	2
	65460	FORK HOLDER - 3-1/2 IN. CROSSBAR	2
4	66378	RETAINING PIN	2
5	812A6	3/8 X 5/8 BUTTONHEAD BOLT	4
	5A220	LANYARD	2
6	81428	BOLT 1/2-13 X 1.25 GRADE 8 SECURE WITH LOCTITE	2
7	81449	BOLT 1/2-13 X 2.5 GRADE 8	2
8	82312	1/2-13 NUT NYLOK	2

Section VI - PARTS (cont'd)

OPTIONAL DASHBOARD PANEL

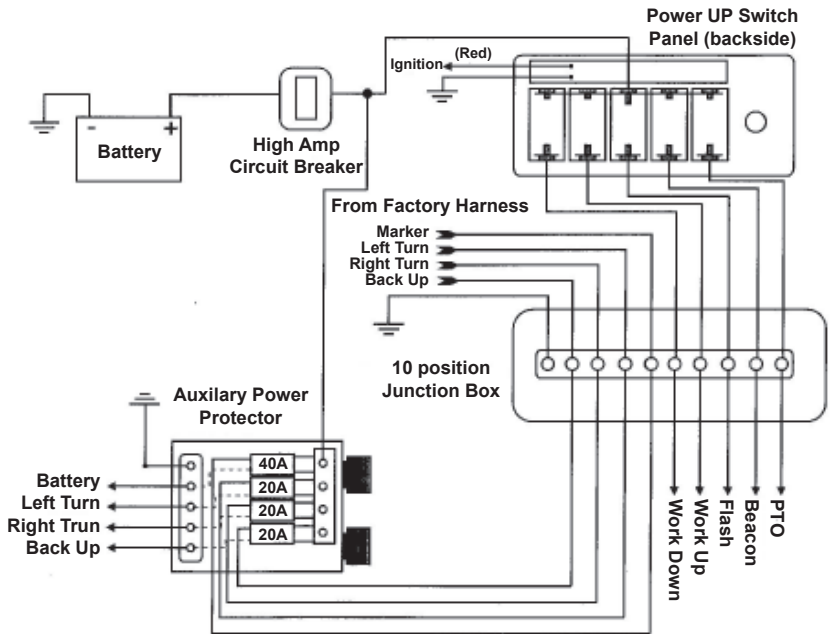

Section VI - PARTS

LIGHT KIT

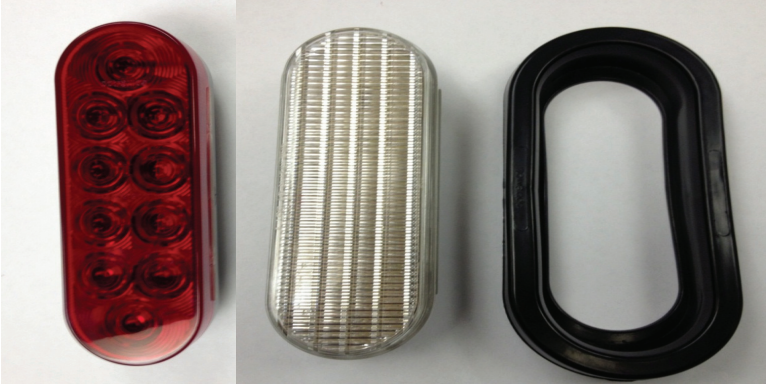

REF. NO.	PART NUMBER	DESCRIPTION
1	0311498	LIGHT 6" OVAL RED LED - STOP/TURN
2	0311500	LIGHT 6" OVAL REVERSE LED
3	3011503	LIGHT 6" GROMMET

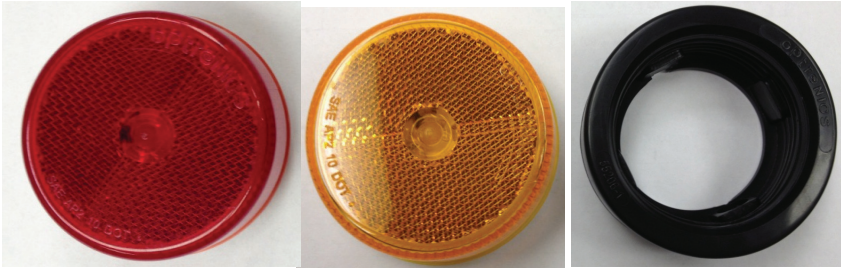

REF. NO.	PART NUMBER	DESCRIPTION
1	0311512	LIGHT 2.5" RED REFLEX LED (MCL59RB)
2	0311513	LIGHT 2.5" AMBER REFLEX LED (MCL59AB)
3	0311516	LIGHT 2.5" GROMMET

Section VI - PARTS

LIGHT KIT



REF. NO.	PART NUMBER	DESCRIPTION
1	0311514	LIGHT 2.5" ROUND CLEAR/RED LED MARKER LIGHT
2	0311515	LIGHT 2.5" ROUND CLEAR/AMBER LED MARKER LIGHT
3	3011516	LIGHT 2.5" GROMMET



REF. NO.	PART NUMBER	DESCRIPTION
1	97300	CONTROL STATION LIGHT

Section VI - PARTS

LIGHT KIT



REF. NO.	PART NUMBER	DESCRIPTION
1	0311519	RED 3/4 LED ICC LIGHT



REF. NO.	PART NUMBER	DESCRIPTION
1	0311520	RED 3/4 LED LIGHT

Section VI - PARTS

LIGHT KIT



REF. NO.	PART NUMBER	DESCRIPTION
1	0311521	AMBER 3/4 ROUND LED LIGHT



REF. NO.	PART NUMBER	DESCRIPTION
1	0311522	CLEAR/RED 3/4 ROUND LED LIGHT



REF. NO.	PART NUMBER	DESCRIPTION
1	0311523	CLEAR/AMBER 3/4 ROUND LED LIGHT

Section VI - PARTS

LIGHT KIT



REF. NO.	PART NUMBER	DESCRIPTION
1	0308359	MARKER LIGHT RED REFLEX LED



REF. NO.	PART NUMBER	DESCRIPTION
1	0308360	MARKER LIGHT AMBER REFLEX LED

Section VI - PARTS

LIGHT KIT



REF. NO.	PART NUMBER	DESCRIPTION
1	0308969R	MARKER LIGHT RED REFLEX LED



REF. NO.	PART NUMBER	DESCRIPTION
1	0308969A	MARKER LIGHT AMBER REFLEX LED

Section VI - PARTS

LIGHT KIT



REF. NO.	PART NUMBER	DESCRIPTION
1	074027041ACL	MILLENIUM MARKER LIGHT CLEAR/AMBER



REF. NO.	PART NUMBER	DESCRIPTION
1	174027041RCL	MELLIENUM MARKER LIGHT CLEAR/RED

Section VI - PARTS

LIGHT KIT



REF. NO.	PART NUMBER	DESCRIPTION
1	0308491	REFLECTOR - AMBER



REF. NO.	PART NUMBER	DESCRIPTION
1	0308490	REFLECTOR - RED

Section VI - PARTS

LIGHT KIT

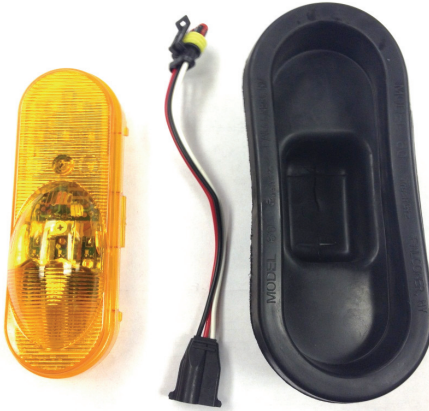

REF. NO.	PART NUMBER	DESCRIPTION
1	0308420	OVAL MID BODY TURN LED
1	0311513	OVAL MID BODY TURN GROMMET

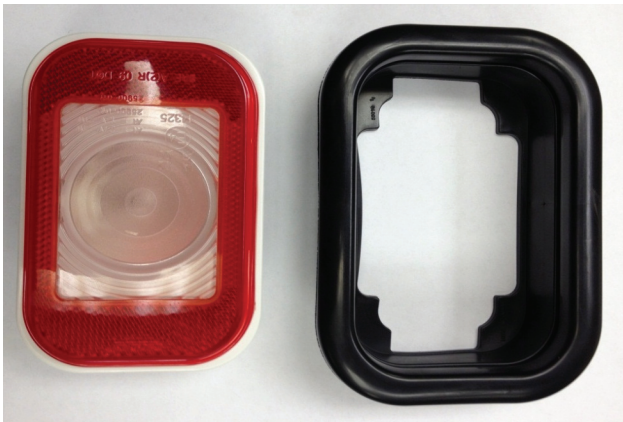

REF. NO.	PART NUMBER	DESCRIPTION
1	0311510	RECTANGULAR REFLEX BACK UP
1	0311511	RECTANGULAR REFLEX BACK UP GROMMET

Section VI - PARTS

33" ALUMINUM TOOLBOX - 377000

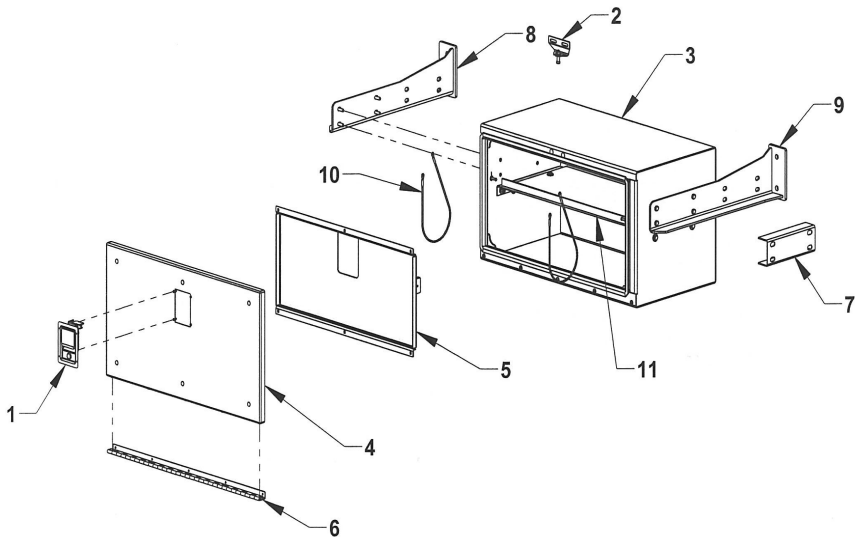

REF	PART #	DESCRIPTION	QPU	
1	54658	ROTARY PADDLE LATCH	1	
	54657	GASKET FOR PADDLE LATCH	1	
	81111	#8-32 X 1/2 STAINLESS ONE WAY SCREW	4	
	83111	#8-32 STAINLESS KEPT NUT	4	
	376183	STRIKER PIN MOUNTING PLATE	1	
2	54659	STRIKER PIN	1	
	81115	STAINLESS CARRIAGE BOLT 5/16-18 x 3/4	2	
	82110	FLAT WASHER 5/16	4	
	82130	LOCK WASHER 5/16	2	
	83110	NUT 5/16-18	2	
	83125	NYLON LOCK NUT 5/16-18	1	
	3	377100W	BOX WELDMENT	1
	4	37741	DOOR WELDMENT	1
		37740	DOOR ASSEMBLY	1
81100		STAINLESS CARRIAGE BOLT 1/4-20 x 3/4	6	
83105		NYLON LOCK NUT 1/4-20	6	
5		37744	DOOR REINFORCEMENT	1
6	37735	HINGE	1	
	811014	SS SOCKET BUTTON HEAD BOLT 1/4-20 x 7/8	2	
	811012	SS SOCKET BUTTON HEAD BOLT 1/4-20 x 3/4	3	
	811010	SS SOCKET BUTTON HEAD BOLT 1/4-20 x 5/8	5	
	83105	NYLON LOCK NUT 1/4-20	10	
7	37760	TANDEM BOX SPACER CHANNEL (OPTIONAL)	1	
8	37855R	TANK AND TOOLBOX MT BRACKET-RIGHT	1	
9	37855L	TANK AND TOOLBOX MT BRACKET-LEFT	1	
10	5A221	LANYARD-21 INCH	2	
11	37770	SHELF	1	

Section VI - PARTS

49" ALUMINUM TOOLBOX - 378000

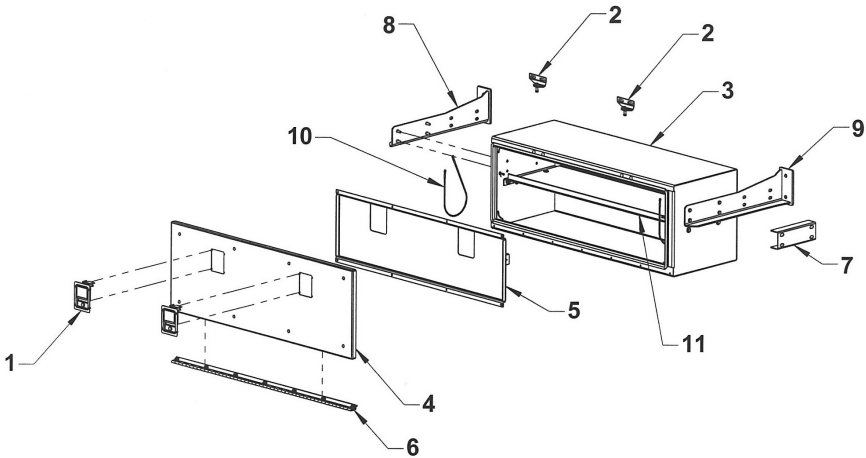

REF	PART #	DESCRIPTION	QPU
1	54658	ROTARY PADDLE LATCH	2
	54657	GASKET FOR PADDLE LATCH	2
	81111	#8-32 X 1/2 STAINLESS ONE WAY SCREW	8
	83111	#8-32 STAINLESS KEPT NUT	8
2	376183	STRIKER PIN MOUNTING PLATE	2
	54659	STRIKER PIN	2
	81115	STAINLESS CARRIAGE BOLT 5/16-18 x 3/4	4
	82110	FLAT WASHER 5/16	8
	82130	LOCK WASHER 5/16	4
	83110	NUT 5/16-18	4
	83125	NYLON LOCK NUT 5/16-18	2
	3	378100W	BOX WELDMENT
4	37841	DOOR WELDMENT	1
	37840	DOOR ASSEMBLY	1
	81100	STAINLESS CARRIAGE BOLT 1/4-20 x 3/4	8
	83105	NYLON LOCK NUT 1/4-20	8
5	37844	DOOR REINFORCEMENT	1
6	37835	HINGE	1
	811014	SS SOCKET BUTTON HEAD BOLT 1/4-20 x 7/8	2
	811012	SS SOCKET BUTTON HEAD BOLT 1/4-20 x 3/4	5
	811010	SS SOCKET BUTTON HEAD BOLT 1/4-20 x 5/8	7
	83105	NYLON LOCK NUT 1/4-20	14
7	37760	TANDEM BOX SPACER CHANNEL (OPTIONAL)	1
8	37855R	TANK AND TOOLBOX MT BRACKET-RIGHT	1
9	37855L	TANK AND TOOLBOX MT BRACKET-LEFT	1
10	5A221	LANYARD-21 INCH	2
11	37670	SHELF	1

Section VI - PARTS

65" ALUMINUM TOOLBOX - 379000

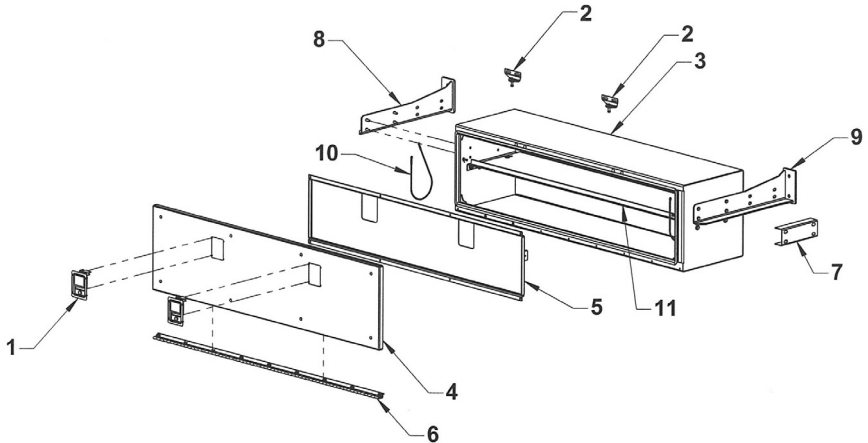

REF	PART #	DESCRIPTION	QPU	
1	54658	ROTARY PADDLE LATCH	2	
	54657	GASKET FOR PADDLE LATCH	2	
	81111	#8-32 X 1/2 STAINLESS ONE WAY SCREW	8	
	83111	#8-32 STAINLESS KEPT NUT	8	
	2	376183	STRIKER PIN MOUNTING PLATE	2
2	54659	STRIKER PIN	2	
	81115	STAINLESS CARRIAGE BOLT 5/16-18 x 3/4	4	
	82110	FLAT WASHER 5/16	8	
	82130	LOCK WASHER 5/16	4	
	83110	NUT 5/16-18	4	
	83125	NYLON LOCK NUT 5/16-18	2	
	3	379100W	BOX WELDMENT	1
	4	37941	DOOR WELDMENT	1
		37940	DOOR ASSEMBLY	1
		81100	STAINLESS CARRIAGE BOLT 1/4-20 x 3/4	8
83105		NYLON LOCK NUT 1/4-20	8	
5		37944	DOOR REINFORCEMENT	1
6	37935	HINGE	1	
	811014	SS SOCKET BUTTON HEAD BOLT 1/4-20 x 7/8	2	
	811012	SS SOCKET BUTTON HEAD BOLT 1/4-20 x 3/4	7	
	811010	SS SOCKET BUTTON HEAD BOLT 1/4-20 x 5/8	9	
	83105	NYLON LOCK NUT 1/4-20	18	
7	37760	TANDEM BOX SPACER CHANNEL (OPTIONAL)	1	
8	37855R	TANK AND TOOLBOX MT BRACKET-RIGHT	1	
9	37855L	TANK AND TOOLBOX MT BRACKET-LEFT	1	
10	5A221	LANYARD-21 INCH	2	
11	37970	SHELF	1	

Section VI - PARTS

LCG RETRACTABLE LADDER

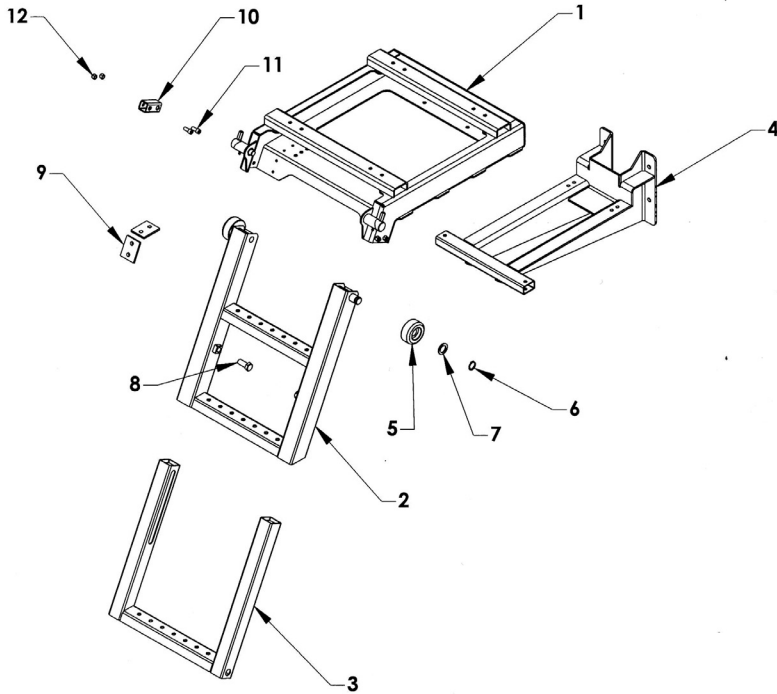

REF	PART #	DESCRIPTION	QPU
	390000	LADDER ASSEMBLY	1
1	391010	LADDER CARRIAGE	1
2	391020	UPPER RUNG ASSEMBLY	1
3	391030	LOWER RUNG ASSEMBLY	1
4	391050	FRAME MOUNTING BRACKET - OPTIONAL	1
5	36310	WHEEL	2
6	86100E	RETAINING RING 1.00 EXTERNAL	2
7	82710	FLAT WASHER 1 x 1.50	2
8	391026	RETAINING BOLT 5/8-11 x 1-1/2	2
9	391018	WEAR PAD	4
10	391015	RETAINING TUBE	2
11	81211	ALLEN HEAD BOLT 3/8-16 x 1	4
12	83211	NYLON LOCK NUT 3/8-16	4