

Vulcan 810 Intruder Maintenance

General

Any equipment requires proper maintenance for long life and normal operation. You should always take the time to lubricate any moving parts and replace any damaged or worn parts. If you follow these guidelines your Vulcan wrecker should operate dependably, efficiently and safely.

Precautions

Always observe these precautions when performing routine maintenance on any hydraulic wrecker.

- * Do not disconnect any hydraulic line that could allow a component to fall or move under its own weight when the hydraulic oil is discharged. Make sure the component is properly supported first.
 - * Do not place your hands near any leaking hydraulic oil that produces a stream or spray. Oil leaking in this manner could inject into your skin, resulting in serious bodily injury.
 - * Never apply lubricant or perform any kind of maintenance while the wrecker is operating under power.
-

Inspection after each use

It is important to visually inspect your equipment after each use.

Pay particular attention to the following areas:

(a) Make sure the winch cable(s) show no obvious damage and that the swaged cable termination at each hook is in good condition. Cable clips are not acceptable. See Figure 5.1.

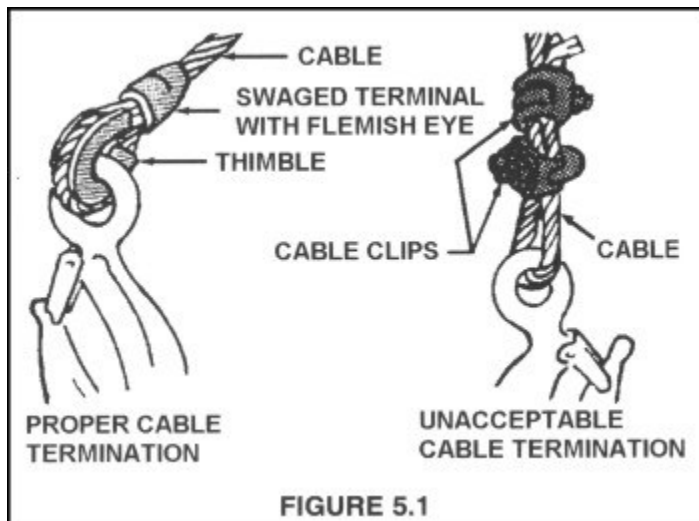

- (b) Sheave wheel housings should be inspected for any sign of wear, bending or damage.
 - (c) Carefully inspect all parts of the recovery boom and all parts of the wheel lift including the crossbar and claws. Check for any bending, cracking or deformation of any parts or welds. Pay attention to paint cracking which may indicate a dangerous condition in the structure beneath.
 - (d) Inspect all safety chains and hook up chains and hooks for bending or damage.
 - (e) Check for loose or missing parts.
-

NOTE:
UNLESS OTHERWISE STATED TORQUE ALL FASTENERS TO VALUES GIVEN IN YOUR OWNER'S MANUAL



IF ANY DEFECT IS FOUND OR THERE IS A MISSING PART, DO NOT OPERATE THE EQUIPMENT UNTIL REPAIRS ARE MADE OR THE MISSING PART IS REPLACED WITH ORIGINAL VULCAN PARTS. TIGHTEN ANY LOOSE HARDWARE. DO NOT ATTEMPT TO BEND METAL BACK TO ITS ORIGINAL SHAPE OR MAKE REPAIRS BY WELDING. FAILURE TO HEED THIS WARNING COULD CAUSE EQUIPMENT FAILURE THAT LEADS TO SERIOUS INJURY OR LOSS OF LIFE.

Daily Safety Inspection

Inspect your wrecker daily to be sure there are no conditions that would adversely affect safety. Inspect items (a) thru (e) above regardless of whether the equipment has been used.

In addition, inspect the following each day:

- (a) Inspect all hydraulic hoses for any sign of wear or leakage.
- (b) Check the truck chassis including the engine compartment, vehicle under clearance, wheels, tires, lights, horns, mudflaps, windshield wipers and transmission fluid level.
- (c) Inspect all pivot pins to ensure they are properly attached and not loose.
- (d) Inspect for any loose or missing hardware bolts or nuts.
- (e) Check all optional equipment and accessories for any wear or damage. Make sure all equipment is stored properly so that it will not fall off and become a hazard to other traffic.
- (f) Make sure the wheel grid system is locked on the crossbar.
- (g) Check all moving parts to make sure there is no excessive wear. Carefully inspect all parts of the recovery boom and all parts of the wheel lift including the crossbar and claws. Check for any bending, cracking or deformation of any parts or welds. Pay attention to paint cracking which may indicate a dangerous condition in the structure beneath.

NOTE:
UNLESS OTHERWISE STATED TORQUE ALL FASTENERS TO VALUES GIVEN IN YOUR OWNER'S MANUAL.



IF ANY DEFECT IS FOUND OR THERE IS A MISSING PART, DO NOT OPERATE THE EQUIPMENT UNTIL REPAIRS ARE MADE OR THE MISSING PART IS REPLACED WITH ORIGINAL VULCAN PARTS. TIGHTEN ANY LOOSE HARDWARE. DO NOT ATTEMPT TO BEND METAL BACK TO ITS ORIGINAL SHAPE OR

**MAKE REPAIRS BY WELDING. FAILURE TO HEED THIS WARNING
COULD CAUSE EQUIPMENT FAILURE THAT LEADS TO SERIOUS
INJURY OR LOSS OF LIFE.**

Monthly Service

You should do a thorough safety check on your truck and equipment every month. This check should be far more thorough than your daily checks. Check the chassis carefully. In addition to the usual chassis maintenance, check wrecker hydraulic hoses and wiring that may be in the engine compartment. Make sure that hoses are not leaking. Make sure all wiring is secure and the insulation is free from damage, especially switch panel wiring.

Make sure there are no loose parts dangling from under the chassis.

Make sure wheels and tires are free from damage and excess wear. Key points to check are as follows:

- (a) Check the oil level of the reservoir with all cylinders fully retracted. The oil should be about two inches from the top of the reservoir filler neck. Add oil if it is lower than that.
 - (b) Unwind the winch cables. Inspect them throughout their lengths. Make sure the cable has no damage and that the swaged cable termination at the hook is in good condition. Check the winches to make sure their mounting bolts are tight and that their parts are free from damage.
 - (c) Check all mounting bolts to make sure they are tight and free from damage.
 - (d) Check all structural members including the wheel lift, crossbar, claws and related components. Extend the stinger to inspect it. Be sure no damaged parts or signs of impending failure are present look closely for hairline cracks, especially in welds. Also look for bent or distorted parts. Make sure no part is missing.
 - (e) Extend the wrecker and wheel lift boom. Inspect sliding surfaces for excess wear. Lubricate the wear pads and sliding surfaces. Replace the wear pads when the sliding surfaces show signs of metal to metal contact.
 - (f) Lubricate all grease fittings. See [lubrication diagram](#)
 - (g) With the PTO disengaged operate the hand held controls. Make sure it does not stick or have excessive play also has a full range of travel when actuated.
 - (h) Make sure the wrecker hydraulic system is free from leaks.
- Make sure hydraulic hoses are secure and have proper clearance from exhaust components, wheels and drive line parts. Make sure there are no kinks or worn places on hydraulic hoses.
- (i) Check the wrecker unit for loose or missing parts. Pay particular attention to fasteners.
 - (j) Pull out the safety chains from their storage compartments and make sure no part of them is damaged or missing.
 - (k) Place towing chains and chains used for recovery on the ground so you can examine all their parts. Make sure no part of them is damaged or missing.
 - (l) Make sure that all loose equipment is properly stowed and none is missing.

**NOTE: UNLESS OTHERWISE STATED TORQUE ALL FASTENERS TO VALUES GIVEN IN
YOUR OWNER'S MANUAL.**



IF ANY DEFECT IS FOUND OR THERE IS A MISSING PART,

DO NOT OPERATE THE EQUIPMENT UNTIL REPAIRS ARE MADE OR THE MISSING PART IS REPLACED WITH ORIGINAL VULCAN PARTS. TIGHTEN ANY LOOSE HARDWARE. DO NOT ATTEMPT TO BEND METAL BACK TO ITS ORIGINAL SHAPE OR MAKE REPAIRS BY WELDING. FAILURE TO HEED THIS WARNING COULD CAUSE EQUIPMENT FAILURE THAT LEADS TO SERIOUS INJURY OR LOSS OF LIFE.

Hydraulic Oil

Check the oil level in the hydraulic reservoir at least once a month.

Avoid overfilling the reservoir. The oil level in the tank should be about two inches below the top of the filler neck. The air space compensates for oil in partially extended hydraulic cylinders and for expansion which occurs when the oil gets hot.

The following is a list of recommended hydraulic oils for your system.

Be sure to use the proper oil for your temperature range. If you are unable to find the oils on this list, use an oil conforming to ISO Grade 46.

Ambient Temperature	Ambient Temperature
Range:	Range:
Above 0 Degrees F.	-20 to 100 Degrees F.
Exxon Nuto H 46	Univis N 46
Amoco AW 46	Amoco Rycon 46
Arco Duro AWS-215	Citgo AW-46 All Temp
Chevron AW-46	Mobil DTE 15
Citgo AW-46	Shell Tellus T 46
Mobil DTE 25	Texaco Rando HD AZ 46
Gulf Harmony 46 AW	Union Unax AW-46
Sun Sunvis 8821 WR	Shell Tellus 46
Conoco AW-46 Super Hydraulic Oil	
Texaco Rando Oil HD 46	

Make sure the hydraulic oil remains clean and free of contamination at all times. Contaminated oil shows signs of turning black when over heated or filled with suspended dirt particles. Oil polluted with water becomes milky in appearance.

During very cold winters, it may become necessary to change to a lighter weight oil.

Oil Filter

Replace the oil filter after the first month of service or the first thirty hours whichever comes first. Replace the filter every six months after the first change. Use filter that is the exact same type as the one furnished.

Always follow applicable local state/provincial, and federal guidelines when disposing of used oil.

Oil

Use motor oil to lubricate moving joints that do not have grease fittings.

Cable Lubricant

Lubricate the winch cables with a lubricant made specifically for wire rope. Do not use motor oil. Wire rope lubricants have specific design qualities. These lubricants penetrate the rope braid. They are free of acids and alkalis. Wire rope lubricants have good adhesive strength. They also resist water and prevent rust.

Winch Gear Box Lubricant

Refer to the winch manufacturer's recommendations for gear box lubricants and filling procedures.

Replacing Parts

Use only genuine Vulcan parts. Never replace factory parts with homemade parts or unknown substitutes.

Vulcan recommends that you return your equipment to your authorized Vulcan distributor for an annual safety inspection and preventative maintenance evaluation.



ALTHOUGH VULCAN MANUFACTURES EQUIPMENT TO WITHSTAND THE RATED LOADS AND DAY TO DAY OPERATIONS CERTAIN PARTS OF THE EQUIPMENT WILL WEAR OUT OVER TIME. IT IS YOUR RESPONSIBILITY TO REPLACE WORN PARTS BEFORE THEY FAIL, TO AVOID EQUIPMENT DAMAGE OR INJURY. A THOROUGH SAFETY INSPECTION WILL ALERT YOU TO PARTS NEEDING REPLACEMENT. REFER TO PAGES V-11 THRU V-15 OF YOUR OWNERS MANUAL WHEN INSPECTING YOUR UNIT.

Lubrication

Lubricate the wrecker at least once a month. Lubricate the wheel lift pivot pin at least once a week.

Use a lithium EP multipurpose grease, NLGI Grade 2, containing three to five percent molybdenum disulfide. It is important to use this type grease when lubricating the wheel lift pivot pin. The following brands conform to the preceding specifications:

* Exxon Beacon Q-2

* Texaco MolyTex EP-2

* Chevron Moly-2

* Amoco Moly-Lith

SEE LUBRICATION CHART BELOW FOR LOCATIONS.

NOTE:
THE ABOVE SERVICE REQUIREMENTS SHOULD BE SERVICED MONTHLY. SERVICE MORE OFTEN IF THE EQUIPMENT IS USED FREQUENTLY.

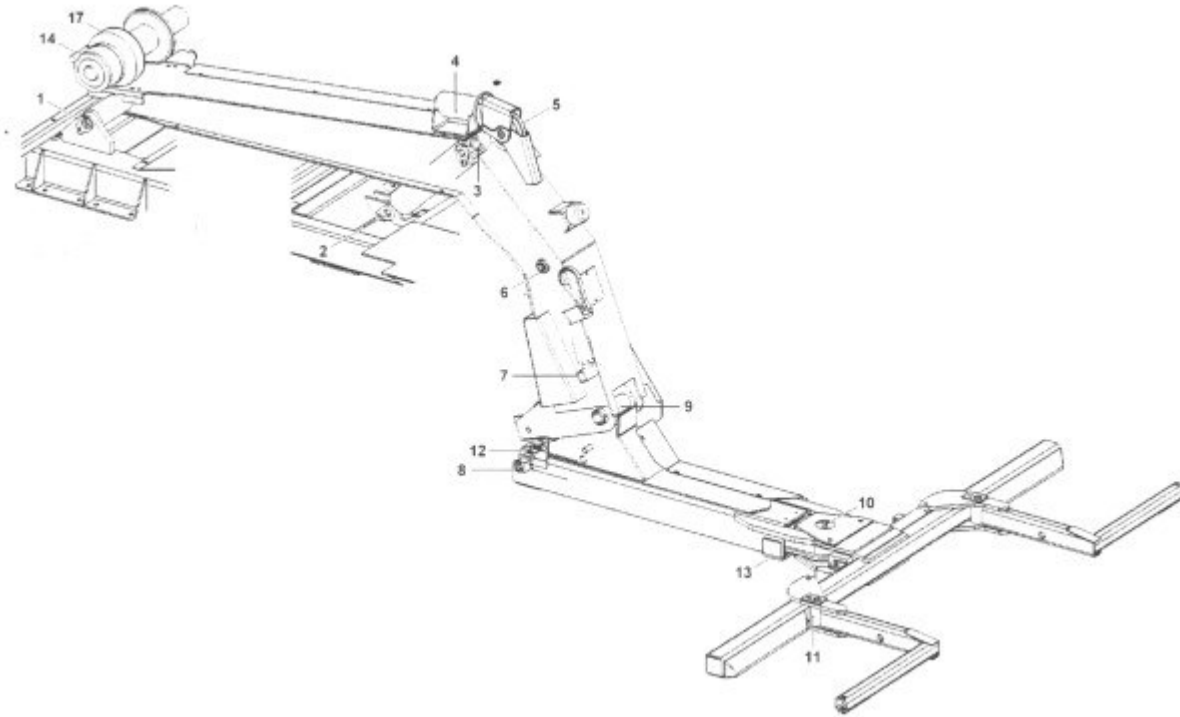

1. Boom Pivot - Grease.
2. Lower Lift Cylinder - Grease.
3. Upper Lift Cylinder - Grease.
4. Sheave Swivel - Grease.
5. Sheave Pivot - Grease.
6. Upper Tilt Cylinder - Grease.
7. Lower Tilt Cylinder - Grease.

8. Stinger Extend Cylinder - Grease.
 9. Wheel Lift Pivot - Grease.
 10. Cross Bar Pivot - Grease.
 11. Claw Arm Pivot - Grease.
 12. Upper Slide Pad - Grease.
 13. Lower Slide Pad - Grease.
 14. Winch Free Spool - Oil.
 15. Winch Cable - Grease.
 16. Tool Box Door Hinge - Oil.
 17. Winch Oil Level.
 18. Hydraulic Reservoir.
-

Troubleshooting

If a functional problem occurs, you should be able to correct it by replacing malfunctioning parts with new ones. Your main concern will be to determine with reasonable certainty what parts are defective. The troubleshooting section that follows should help you to isolate the defective parts.



**NEVER ATTEMPT TO DISCONNECT A HYDRAULIC HOSE
WITHOUT FIRST BLOCKING THE EQUIPMENT SO THAT IT
CAN NOT FALL.**

PROBLEM: OIL GETS EXCESSIVELY HOT	
Probable cause:	Remedy:
Oil level low	Fill to proper level.
Dirty oil	Drain oil reservoir change oil and filter
Defective pump	Replace pump
PROBLEM: OIL FOAMY	
Probable cause:	Remedy:
Air Leak in Suction Line	Tighten Connections
Wrong type of Oil	Change Oil
Oil Level Low	Fill to Proper Level
PROBLEM: ALL CONTROL FUNCTIONS SLUGGISH	
Probable cause:	Remedy:

Collapsed or blocked suction hose	Repair or replace hose.
Defective pump	Operate engine speeds higher than normal. If functions improve change pump
Oil level low	Fill to proper level
PROBLEM: BOOM DROPS WHILE TOWING	
Probable cause:	Remedy:
Improper lock valve adjustment	Adjust the lock valve.
Dirt between seat of lock valve or bad lock valve	Clean and reassemble or replace the lock valve.
Defective lift cylinder	Repair or replace the lift cylinder.
PROBLEM: BOOM WILL NOT LOWER	
Probable cause:	Remedy:
Improper adjustment of lock valve	Adjust lock valve
Defective directional control valve	Repair or replace valve.
PROBLEM: ENGINE STALLS UNDER LOAD	
Probable cause:	Remedy:
Engine speed too low	Adjust engine RPM
Improper adjustment of relief valve	Adjust pressure to 2500 PSI
PROBLEM: BOOM STALLS UNDER LOAD	
Probable cause:	Remedy:
Improper relief valve setting	Lubricate and replace pads if necessary
PROBLEM: UNDERLIFT WILL NOT RETRACT LOAD	
Probable cause:	Remedy:
Slide pads worn or not lubricated	Lubricate and replace pads if necessary.
Low pressure setting	Set pressure to 250 PSI
Collapsed or blocked cylinder hoses	Repair or replace hoses as necessary.

