

Vulcan 896/897 Safe Steering Load, GVWR, GAWR & GCWR

Chassis Limitations

Safe operation of your equipment is limited not only by the ratings of

your equipment, but also by the amount of weight remaining on the front axle when towing and by your chassis ratings. When towing a vehicle it is important that you:

(a) Maintain at least 50% of the original weight on your front axle for

steering. 50% is generally accepted by the towing industry as the amount of original front axle weight that should be maintained on the front axle for safe steering under good towing conditions on paved surfaces. More than 50% of the original front axle weight should be maintained on the front axle when towing on gravel roads, wet surfaces, snow or other adverse towing conditions.

Furthermore, information may be available from your chassis

manufacturer that tells you to maintain a specific amount of weight on the front axle of your chassis for safe steering. If the chassis manufacturer recommends that you should maintain more weight on your front axle than safe steering formula indicates, then you should adhere to the manufacturer's recommendation.

(b) Do not exceed the GVWR (Gross Vehicle Weight Rating) of your chassis when you are towing a load. Exceeding the GVWR of your chassis can affect its braking and handling.

(c) Do not exceed the GAWR (Gross Axle Weight Rating) of your truck.

(d) Do not exceed the GCWR (Gross Combination Weight Rating) of your truck. Exceeding the GCWR can affect braking and handling of your chassis.

When you obtain a tow truck, you should calculate its maximum load for safe steering. If it has more than one towing device installed, you should make the calculation for each device. You should record that information on a sticker and put it in the cab within easy view of the driver/operator. All drivers should be required to observe the limits shown on the sticker. Decals for this purpose are available from Vulcan.

The maximum towing load for safe steering is the maximum load that can be lifted without making the tow trucks steering traction unreliable and dangerous. It should be calculated after all equipment is mounted.

Weight on the steering wheels should NOT be reduced to less than one-half of their unladen weight.

A simple formula for calculating the maximum lifted load for safe steering is shown below. It is based on the requirement for maintaining one-half the unladen steering weight.

This formula has been used by the towing industry for many years and has proven reliable for determining the maximum lifted load for safe steering under good towing conditions as stated above.

$$ML = 1/2 FAW \times WB / OH$$

where:

AL = maximum lifted load for safe steering.

FAW = the unladen (unloaded) weight at the front axle.

WB = wheel base (distance between the center of the front axle

and the center of the rear axle(s)

OH = overhang (distance from the center of the rear axle(s) to the lift point of the towing device.

To use the formula, divide the unladen weight at the front axle by two. Multiply the result by the wheel base. Then divide that result by the overhang. The last number you get is the maximum lifted load for safe steering.

Use the step by step instructions that follow to calculate safe steering tow loads for various types of towing devices. Do the calculations for each type of towing device installed on your tow truck.

Use this procedure to calculate the maximum tow load when using a wheel lift, under lift, towing sling, tow bar, or truck hitch. Use this procedure only for those devices mounted on a tow truck.

Calculations for car carriers are not covered in this manual. They require additional calculations because vehicles may be carried on their beds.

You can use pounds and inches or centimeters and kilograms in your calculations. If you use kilograms instead of pounds and centimeters instead of inches. The safe steering limits will be in kilograms. Do not mix pounds and kilograms, nor inches and centimeters in the same calculation. If you use kilograms, convert the chassis ratings to kilograms before making calculations.

(a) Weigh the truck at its front and rear wheels and note the weight in either pounds or kilograms. Make sure the truck has a full tank of fuel, that the driver is in the cab, and that the truck is unloaded, except for usual towing equipment. On trucks with tandem axles, include the combined weight of both rear axles. See Figure 1A.1.

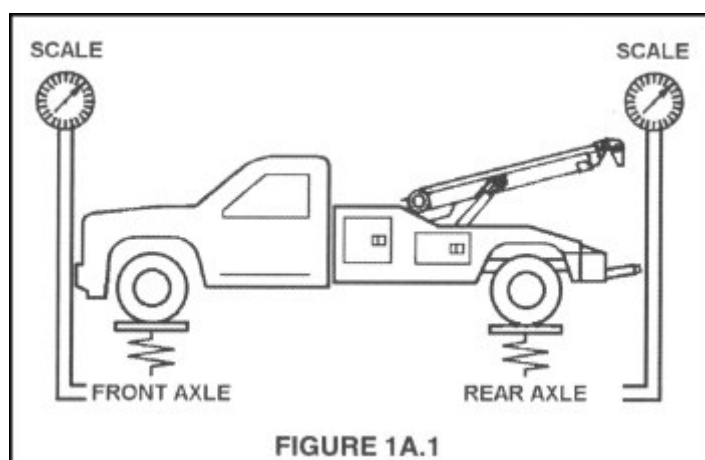

(b) Carefully measure the wheel base and note the distance in either inches or centimeters. See Figure 1A.2.

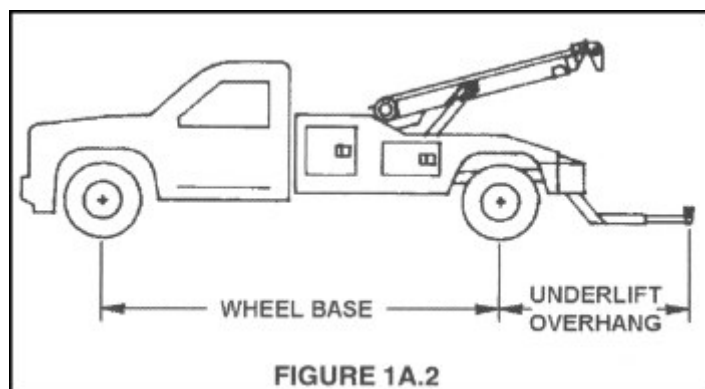

(c) Measure the overhang and note the distance in either inches or centimeters. See Figure 1A.3.

NOTE:
THE TOWING DEVICE MUST BE IN ITS POSITION NORMALLY USED FOR TOWING!
OTHERWISE, THE TOWING LIMITS WILL BE WRONG.

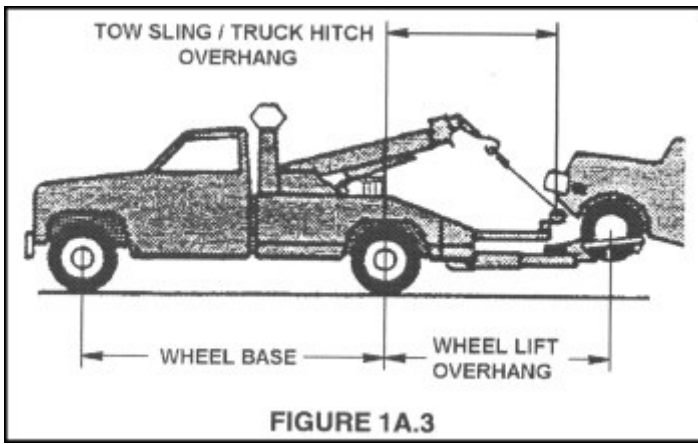

FIGURE 1A.3

(d) Divide the front axle weight by 2.

(e) Multiply the result of step 4 by the wheel base.

(f) Divide the result of step 5 by the overhang. The result is the maximum load that the truck can lift and maintain safe steering.

Example for a wheel lift:

Assume you found the following for your tow truck: See Figure 1A.4.

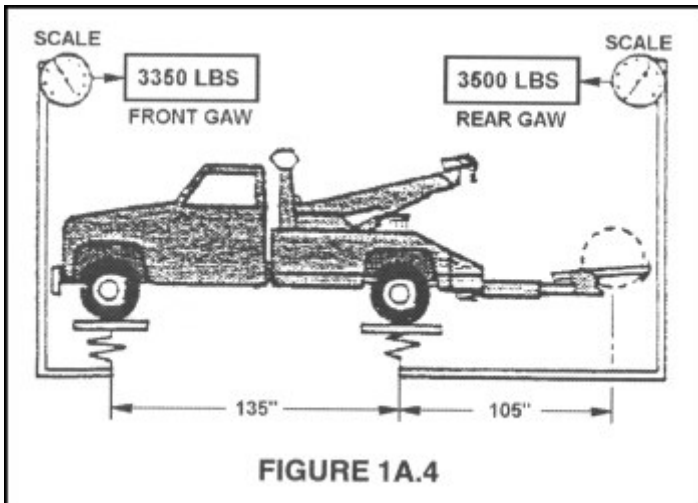

FIGURE 1A.4

- 3350 pounds front axle weight
- 3600 pounds rear axle weight
- 135 inches wheel base distance
- 105 inches overhang distance

Now, make these calculations:

- 3350 divided by 2 is 1675
- 1675 multiplied by 135 is 226125
- 226125 divided by 105 is 2154

In the above example, 2154 pounds is the maximum safe steering load that should be lifted by the wheel lift at its usual towing position.

Remember, this is the maximum load that should be lifted with the wheel lift under good towing conditions.

Calculating GAW, GVW, and GCW

For many tow trucks, the maximum load for safe steering will limit your tow load more than any other factor. The rear axle rating is usually the next most important factor. If the chassis is larger than usual, the lift rating of the towing devices is likely to be the limiting factor.

Always consider those other factors and adjust tow load limits so you will not exceed the lowest limit or rating.

For example, consider a light duty wheel lift on a Ford Super Duty chassis with an 84-inch CA. The wheel lift rating is likely to be lower than the maximum load for safe steering. If so, the wheel lift rating may be the limiting factor.

GAWR and GVWR are often the limiting factors when tow equipment is mounted on the minimum recommended chassis. Always compute the GAW and GVW and compare them to the chassis GAWR and GVWR to see if you should reduce your tow loads to avoid exceeding those chassis ratings.

Simply add certain numbers from previous calculations to determine GAW (Gross Axle Weight) and GVW (Gross Vehicle Weight). Compare what you get with the chassis GAWR and GVWR. That will tell you if your chassis will be loaded within its ratings when towing the maximum load for safe steering.

Example of Calculating Rear Axle GAW

This example uses numbers from the previous example to show the types of information to use:

$$\begin{array}{r} 1675 \text{ 1/2 the front axle weight} \\ + 2154 \text{ maximum load for safe steering} \\ + 3600 \text{ unloaded rear axle weight} \\ \hline 7429 \text{ GAW of rear axle (See Figure 1A.5.)} \end{array}$$

Thus, the rear GAWR of the truck chassis used in the example should be at least 7429 pounds.

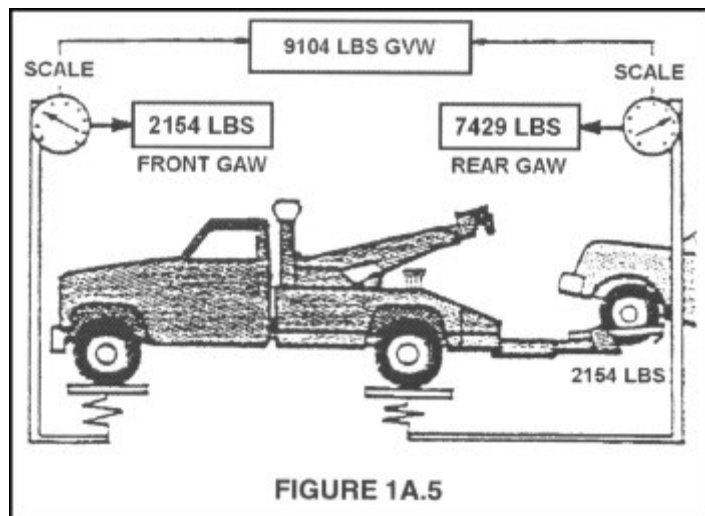

Example of Calculating GVW

This example uses numbers from the earlier example to show the types of information to use:

$$\begin{array}{r} 3350 \text{ unloaded weight of the front axle} \\ + 3600 \text{ unloaded weight of the rear axle} \\ + 2154 \text{ maximum load for safe steering} \\ \hline 9104 \text{ GVW (Refer to Figure 1A.5.)} \end{array}$$

Thus, the GVWR of the truck chassis used in the example should be at least 9104 pounds.

Example of Calculating GCW

To calculate GCW, simply add the total weight of your tow truck plus the total weight of the vehicle you intend to tow.

For example, suppose you intend to tow a vehicle that weighs 4,000 pounds.

The following example uses numbers from the earlier example to show the types of information to use:

3350 unloaded weight of the front axle
+ 3600 unloaded weight of the rear axle
+ 4000 weight of towed vehicle

10950 GCW

Thus, the GCWR of the truck chassis used in the example should be at least 10,950 pounds.

Remember, these are only examples. You must use the actual weights and dimensions of your tow truck when calculating GAW, GVW and GCW.

Weights for most vehicles that you might encounter when towing can be obtained from various trade sources and consumer report magazines. We suggest that you acquire such information to help you stay within the ratings of your equipment and chassis.